

2004 MAZDA3 CRASH ZONE SENSOR [RECALL 2304J]

**A. VEHICLE INSPECTION PROCEDURE**

1. Verify that the vehicle is within the following ranges:
  - 2004 MAZDA3 vehicles built between June 24, 2003 through March 22, 2004  
VIN Range: JM1BK\*\*\*\*41 100088 – JM1BK\*\*\*\*41 169916
  - If the vehicle is within the above range, proceed to step 2.
  - If the vehicle is not within the above range, return vehicle to the customer or inventory.
2. Perform a Warranty Vehicle Inquiry using your eMDCS System and inspect vehicle for an Authorized Modification Label **Recall 2304J** attached to the vehicle’s hood. Refer to eMDCS System - Warranty Vehicle Inquiry Results table below.

**NOTE:** Be sure to verify RECALL number as the vehicle may have multiple Recall labels.

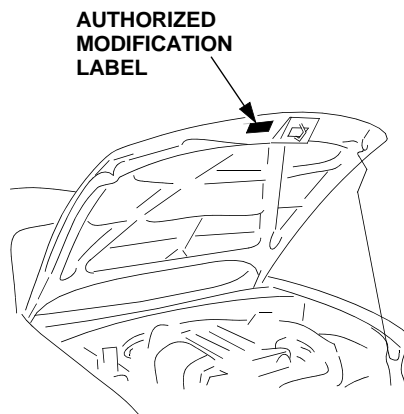

**eMDCS System - Warranty Vehicle Inquiry Results:**

If eMDCS displays:	Campaign Label is:	Action to perform:
RECALL 2304J OPEN	Present	Contact the Mazda Corporate Dealer Assistance Group at (877) 727-6626 to update vehicle history.
	Not present	Proceed to “B. INSPECTION PROCEDURE”.
RECALL 2304J CLOSED	Present	Return vehicle to inventory or customer.
	Not present	Complete a label and apply to vehicle’s hood.
RECALL 2304J is not displayed	Does not apply	Recall does not apply to this vehicle. Return vehicle to inventory or customer.

## B. INSPECTION PROCEDURE

1. Open the hood.
2. Remove cover of crash zone sensor (CZS).

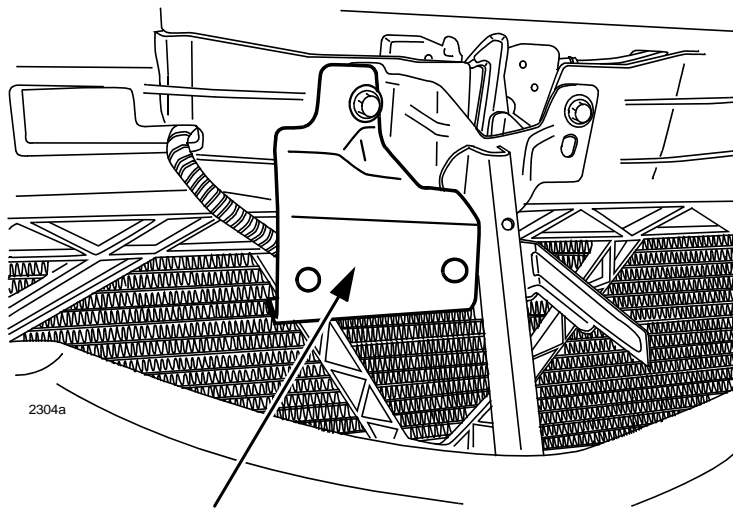

REMOVE COVER  
OF CRASH ZONE  
SENSOR

3. Inspect bolt for presence of white silicon at bolt head, end of bolt, and on top of the CZS surfaces.
  - If silicon is present, install cover, install recall sticker on hood, and return vehicle to the customer or inventory.
  - If silicon is not present, proceed to REPAIR PROCEDURE.

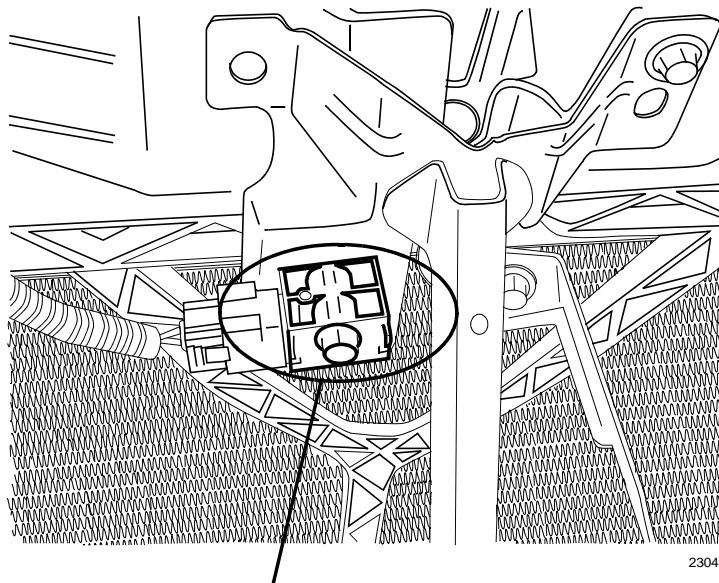

INSPECT THE PRESENCE OF WHITE SILICON  
AT BOLT HEAD, END OF BOLT, ON TOP OF,  
AND SURROUNDING SURFACES  
OF CRASH ZONE SENSOR

## REPAIR PROCEDURE

**CAUTION:** Do not apply silicon to vehicle as this will affect sensor operation. Service parts must be used.

1. Record all radio station presets so you can re-program customer preferences after repairs are completed.
2. Remove ignition key from key switch.
3. Disconnect the negative battery cable and wait for **1 min or more**.
4. Mark original location of latch using a scribe, masking tape, or suitable marker.

### LATCH ASSEMBLY

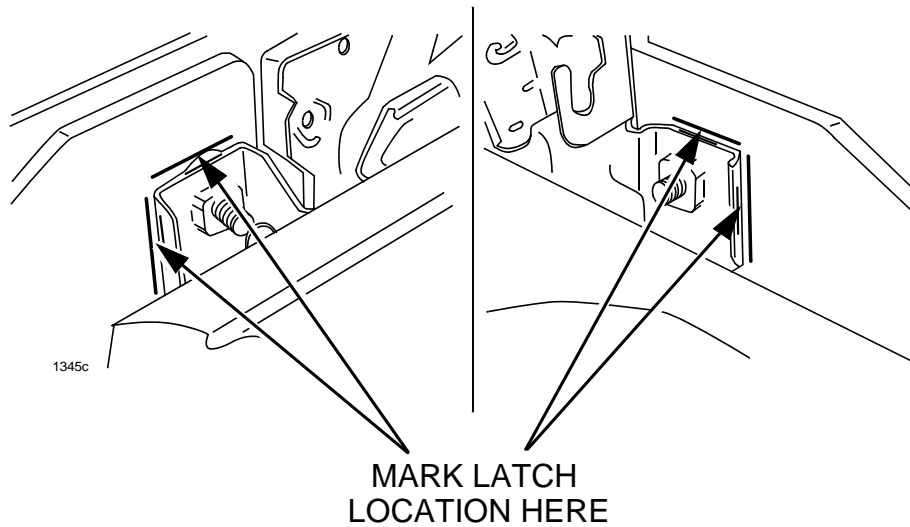

5. Replace center stay assembly with CZS, P/N BPYK-57-KX0 and reinstall cover of CZS. Be sure to torque all four (4) center stay bolts.

**Tightening Torque: 7.9 - 11.7 N-m (70 - 103 in-lbf)**

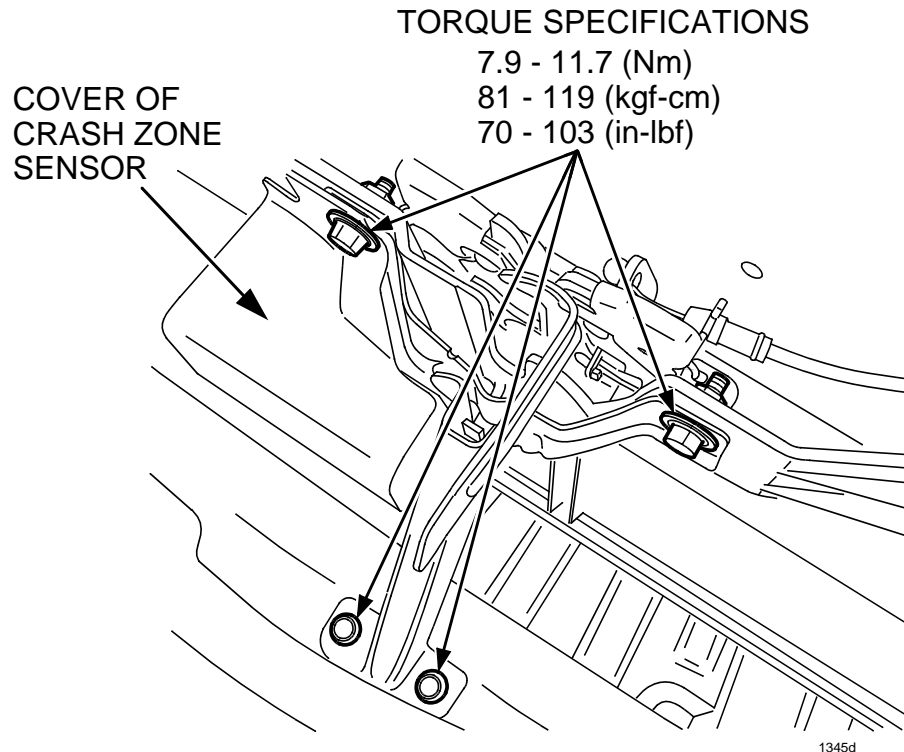

6. Close hood gently and check for flushness with fender or unusual gaps. Adjust hood bonnet if needed. Refer to Workshop Manual (section 09-10 HOOD ADJUSTMENT).
7. Reconnect negative battery cable.
8. Using WDS, delete DTC(s) from the SAS unit.
9. Verify repair by confirming airbag warning light is off.
10. Re-program the clock and recorded preset radio stations.

#### **D. AUTHORIZED MODIFICATION LABEL INSTALLATION**

Complete an "Authorized Modification Label" with the Recall number written on the sticker and affix it to the vehicle's hood. Refer back to the illustration under "A. VEHICLE INSPECTION PROCEDURE".