

A. VEHICLE INSPECTION PROCEDURE

1. Inspect vehicle for a Campaign Label **6411F** attached to the vehicle's hood or bulkhead.

Campaign Label is:	Action to perform:
Present	Contact the Warranty Hotline at (877) 727-6626 option 3 to update vehicle history.
Not present	Proceed to "B. REPAIR OUTLINE".

NOTE: Verify Recall number as the vehicle may have multiple Recalls.

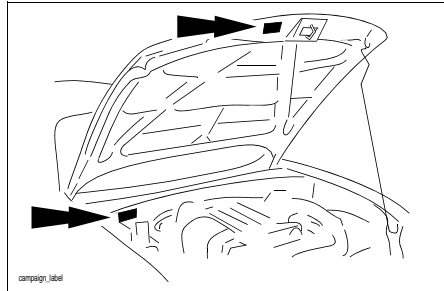

CAMPAIGN LABEL

CAMPAIGN NO: _____

DEALER CODE: _____

DATE: / /

P/N 9999-95-065A-06

1326b

B. REPAIR OUTLINE

PARTS INFORMATION

Ground Harness Kit (Part # BNY0-67-352)

A: Washer

B: Ground Bolt (Tapping Screw)

C: Ground Harness (with heat shrink at one end)

D: Bands (Tie Wraps)

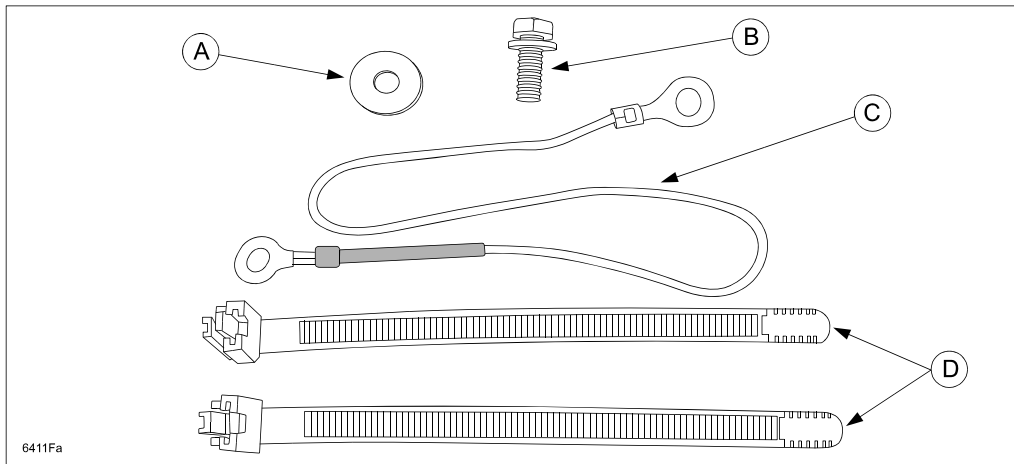

1. Remove the wiper arms with blades and the cowl grille.

NOTE: Use caution when removing the cowl grille, covers and clips.

2. Add a ground harness (A) to the wiper motor (B) and vehicle body using a ground bolt (C) and washer (D). The side of the ground harness with the heat shrink tube should attach to the wiper motor, and the other end of the ground harness attaches to the ground bolt. Two tie wraps are used to secure the wire to the main link.

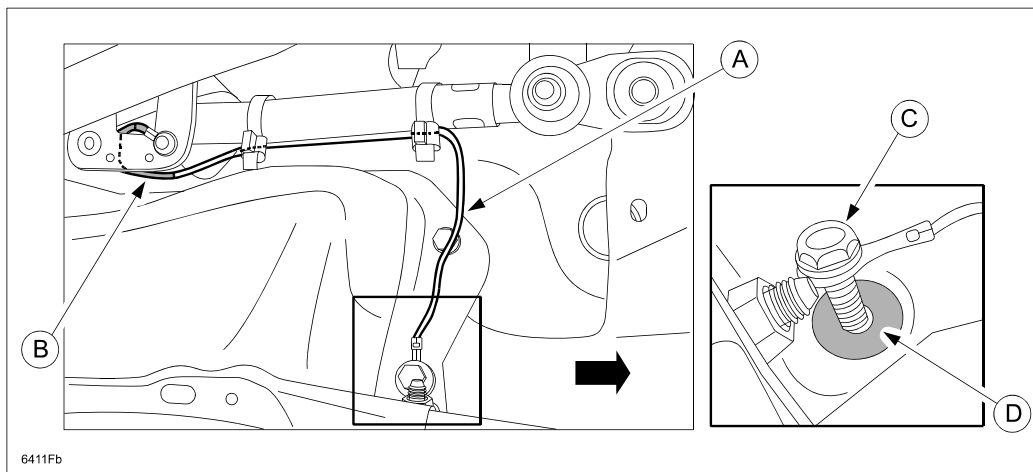

C. REPAIR PROCEDURE

COWL GRILLE REMOVAL

1. Verify that the front wiper motor switch is in the OFF position.
2. In order to prevent the wipers from being activated by mistake during the repair, remove the key from the ignition.
3. Remove the windshield wiper arms and blades.

NOTE: Mark location of wiper arms to connector shafts.

- Remove the caps (A).
- Remove the nuts (B).
- Remove the windshield wiper arms and blades.

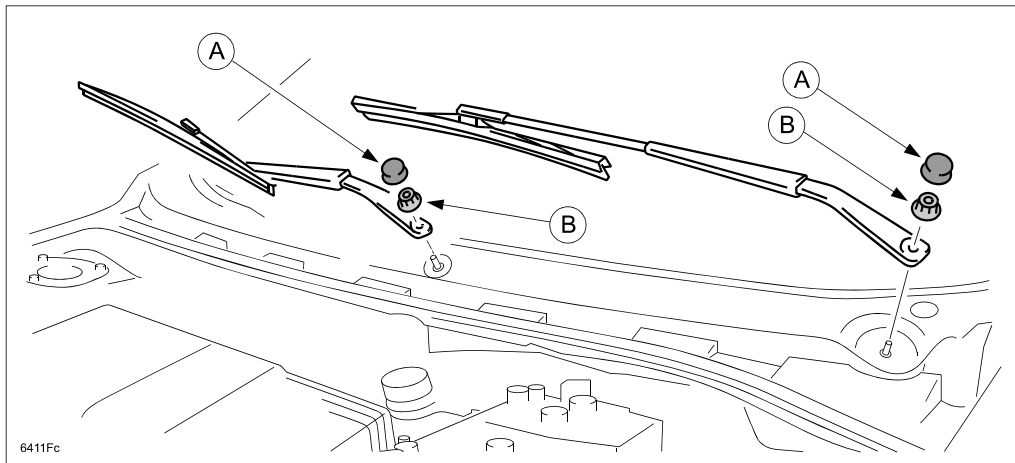

4. Remove the cowl grille(s).

For MAZDA3:

- Remove the left cowl grille.
 - Using a small flathead screwdriver, remove the left side cap (A), **taking care not to damage the cap** (BP4M-50-705).
 - Remove the screw under the cap.
 - Detach the three clips (B), then remove the weatherstrip.

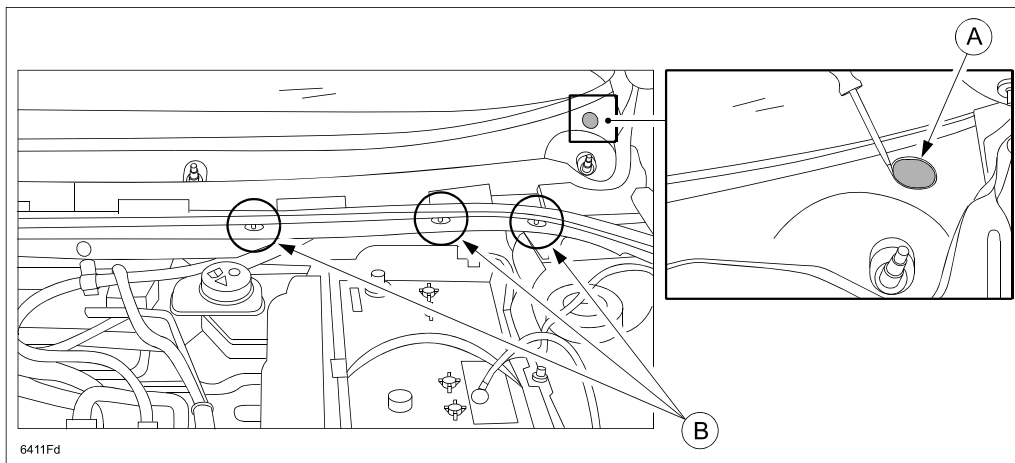

NOTE: To detach the clips, pinch them from the bottom using pliers.

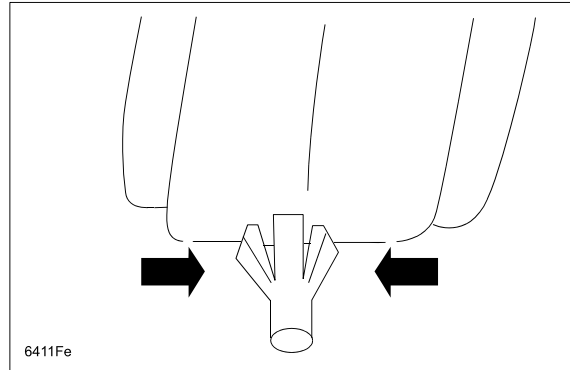

- Move the left cowl grille in the direction indicated by the arrow and disengage tabs A from the windshield (B).

CAUTION: Take care not to damage the clips when removing the left cowl grille.

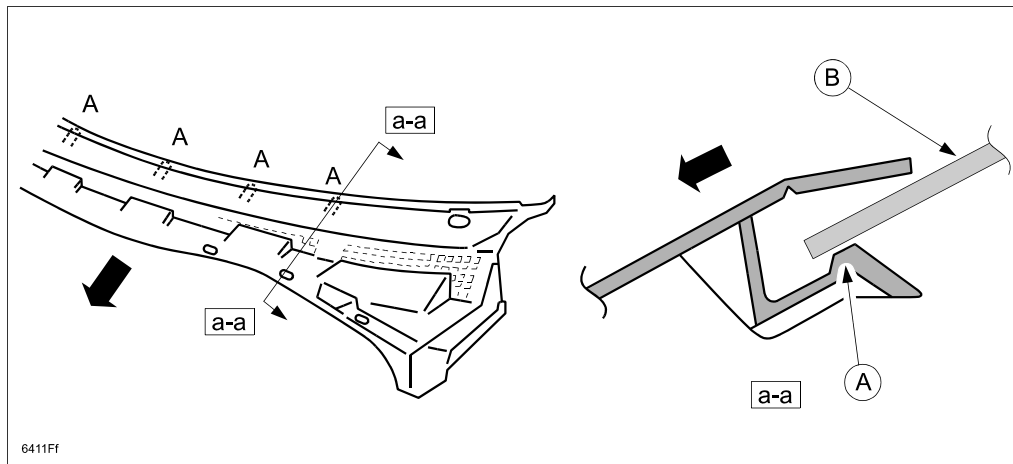

- Remove the left cowl grille.

For MAZDASPEED3:

- Remove the cowl grilles.
 - Using a small flathead screwdriver, remove the caps (A), **taking care not to damage the caps** (BP4M-50-705).
 - Remove the screws under the caps.
 - While leaving one clip alone (B), detach all other clips to remove the weatherstrip (C).

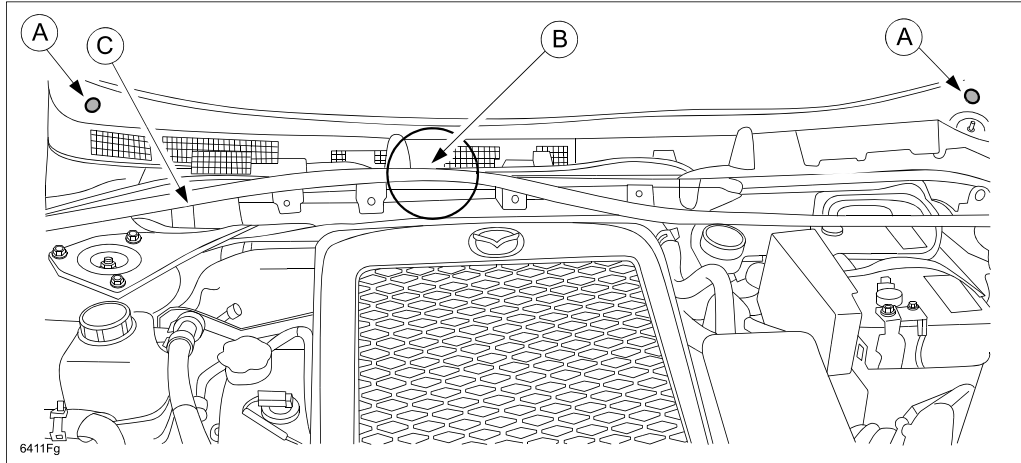

NOTE: To detach the clips, pinch them from the bottom using pliers.

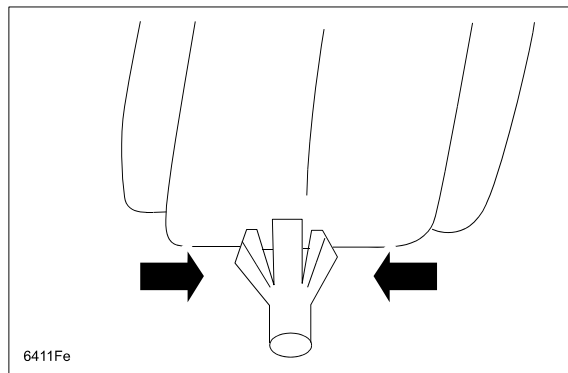

- Move the cowl grilles in the direction indicated by the arrow and disengage tabs (A) from the windshield (B).

CAUTION: Take care not to damage the clips when removing the cowl grilles.

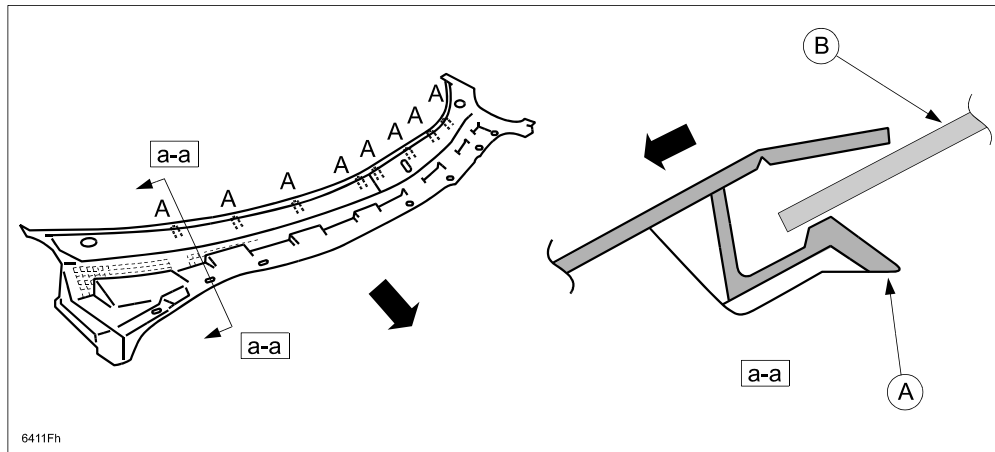

NOTE: When putting the cowl grille back after the repair, install from right cowl grille.

- For the right cowl grille (B), disconnect the joint pipe (C), then pull the windshield washer hose (D) in the direction of the arrow and remove it from clip (A).

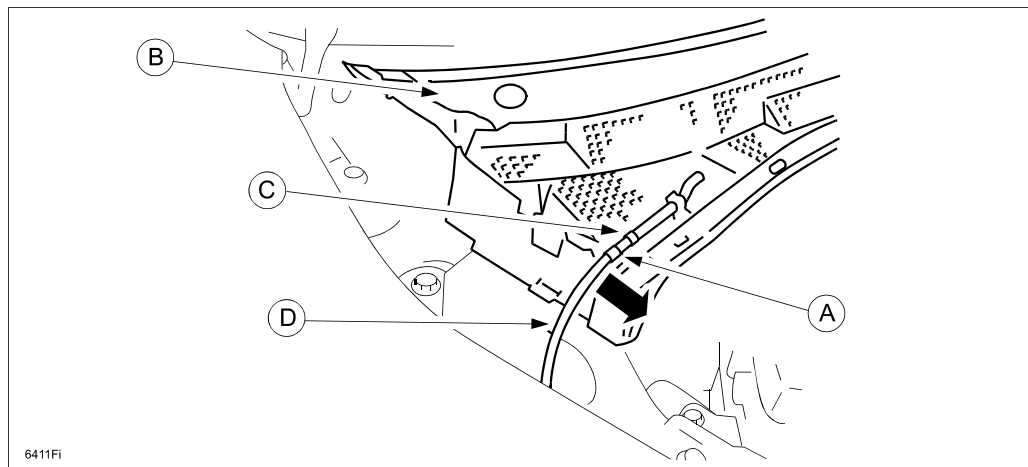

- Remove the cowl grilles.

GROUND HARNESS INSTALLATION

1. To make more working space, remove the left bolt (A) and turn the right bolt (B) one turn counterclockwise, then slightly pull the wiper motor forward.

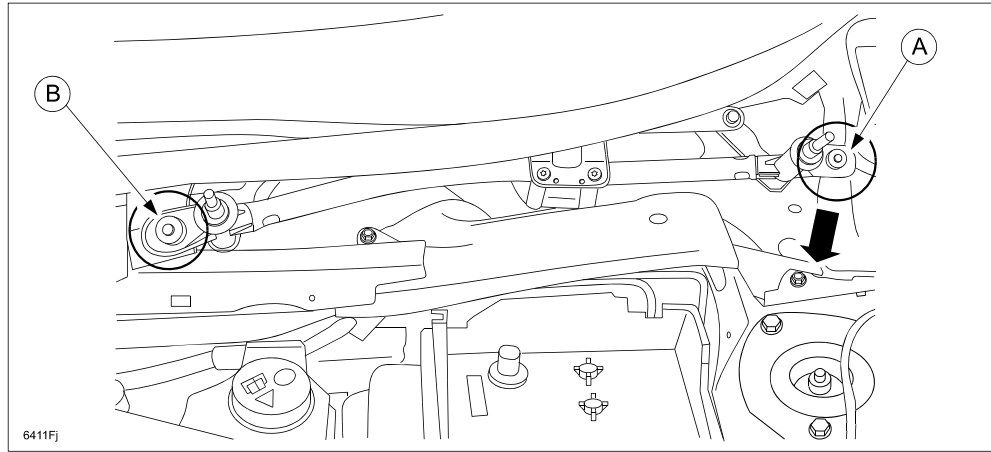

2. Remove the screw from the wiper motor using a T-30 Torx bit.

CAUTION: Be careful not to hit the windshield with the tools.

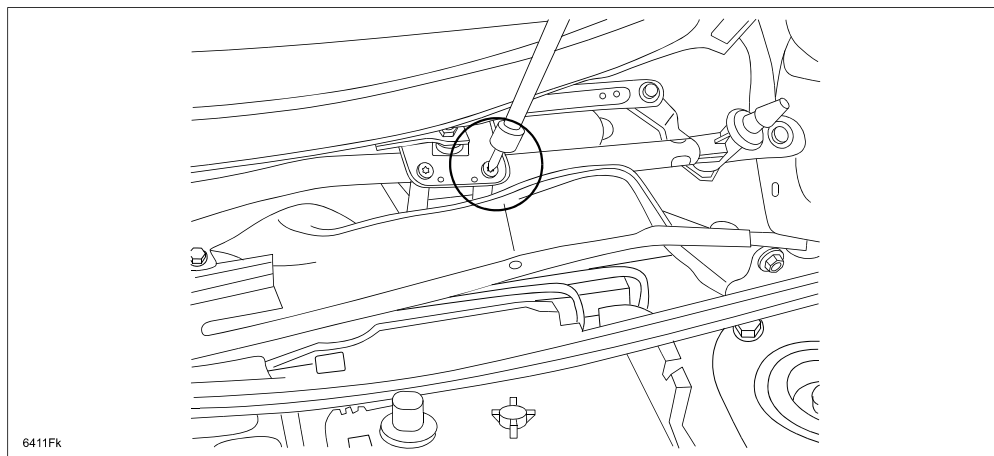

3. Insert the ground harness terminal with heat shrink (A) and crimped end (B) between the bracket (C) and the main link (D).

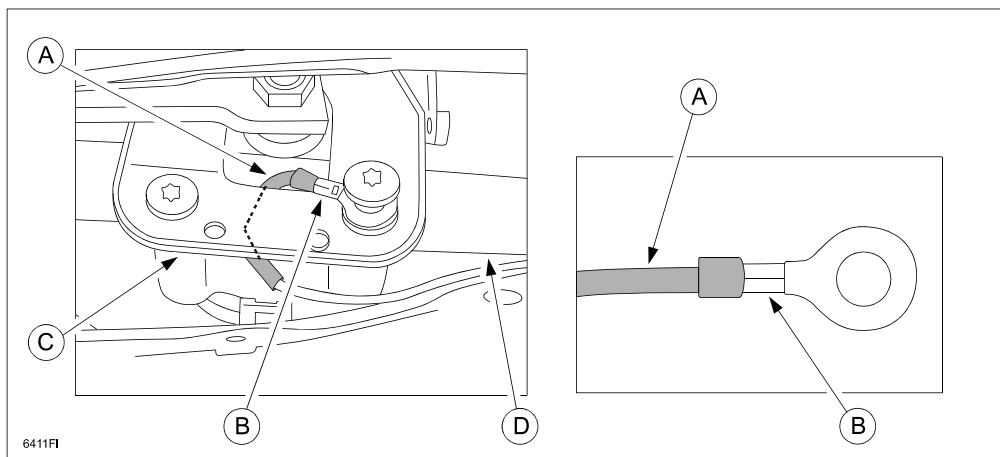

ATTACHMENT II - REPAIR PROCEDURE
Safety Recall 6411F

4. With the crimped side facing upward, fix the terminal to the wiper motor, routing the harness along the bracket .

Tightening torque: 8-9 N·m {82-91 kgf·cm, 71-79 in·lbf}

CAUTION: While tightening the bolt, hold the terminal by hand to prevent it from turning and touching the link

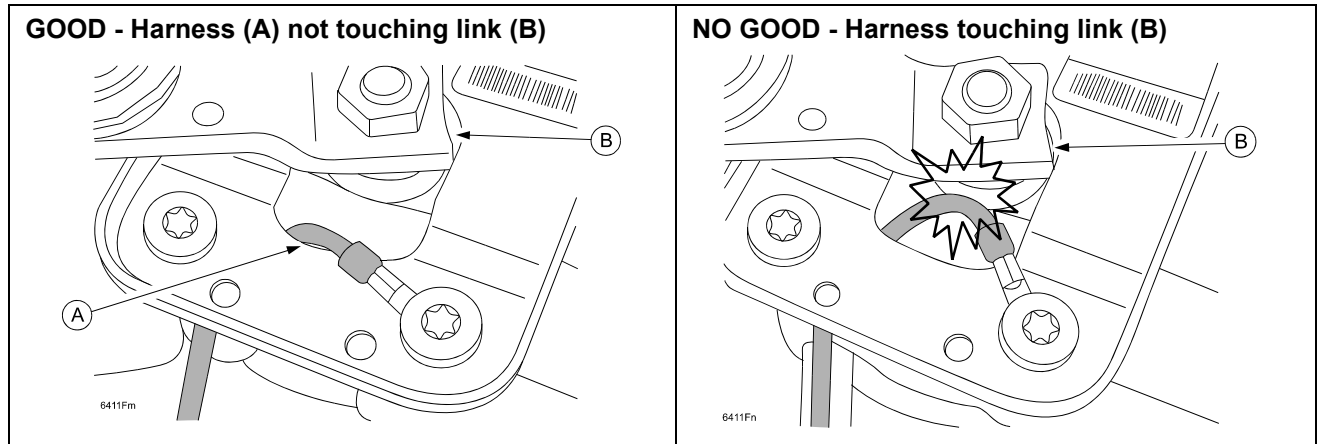

5. Remove the bolt (A) from the cowl panel.

NOTE: Discard the original bolt.

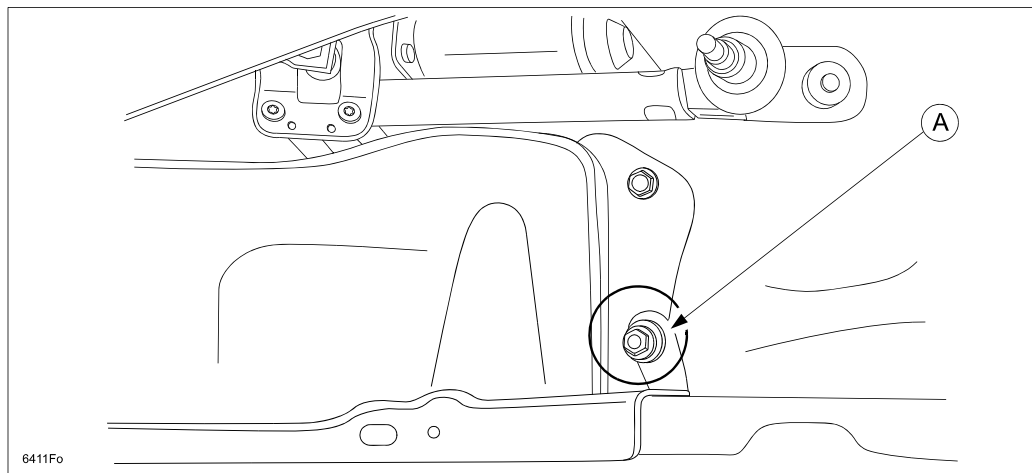

ATTACHMENT II - REPAIR PROCEDURE
Safety Recall 6411F

6. With the crimped side facing upward (A), insert the new ground bolt (B) to the cowl panel through the terminal and washer (C).

CAUTION: Make sure to put the new washer between the terminal and the cowl panel, otherwise water may enter into the engine compartment.

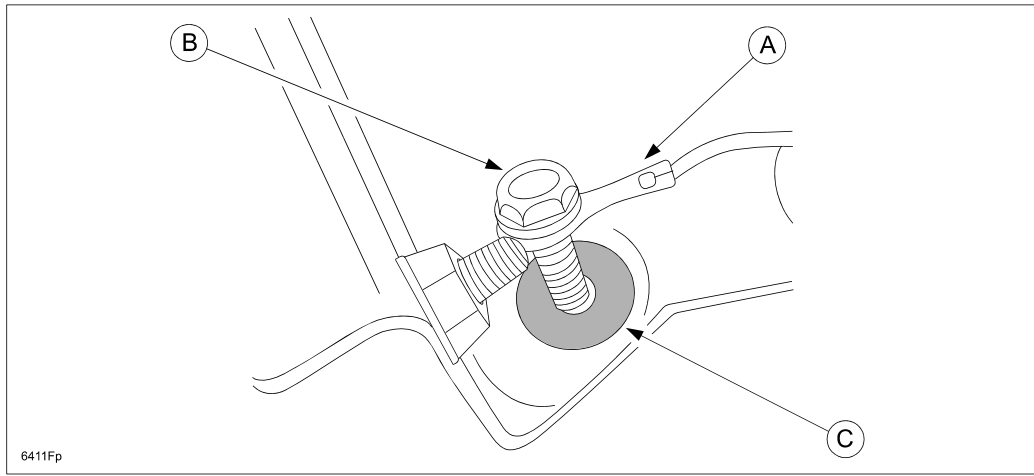

7. With the crimped side facing upward and harness routed along the main link (A), tighten the new ground bolt (B).

Tightening torque: 10-12 N·m {102-122 kgf·cm, 89-106 in·lbf}

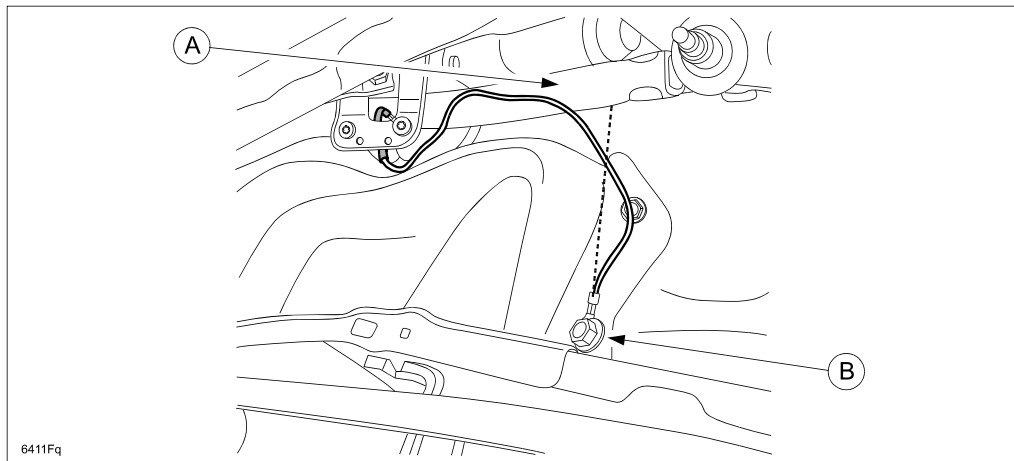

8. Temporarily fix the harness to the main link with the two tie wraps.
Location of Tie Wrap (A): 25mm from the edge of the bracket (C) to the tie wrap.
Location of Tie Wrap (B): 25mm from the end of the main link pipe (D) to the tie wrap.

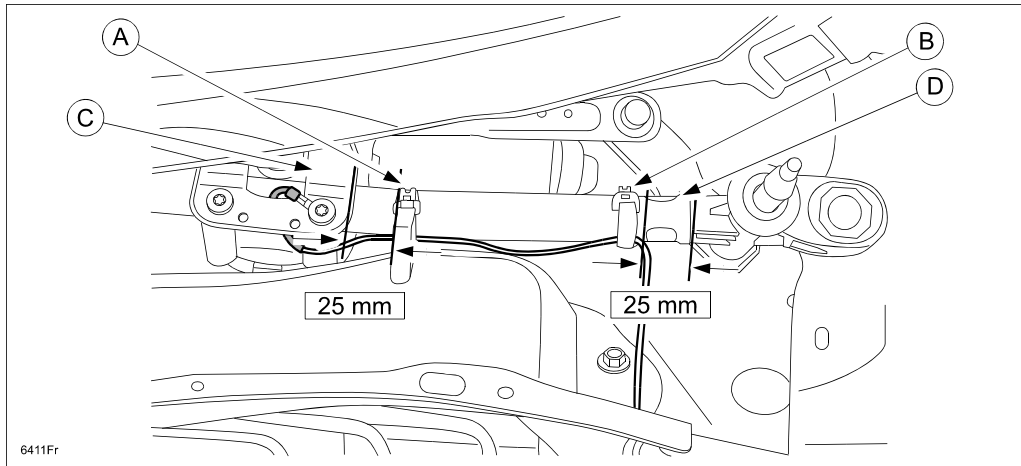

9. Tighten the main link bolts (A).
Tightening torque: 4.0-6.8 N·m {41-69 kgf·cm, 36-60 in·lbf}

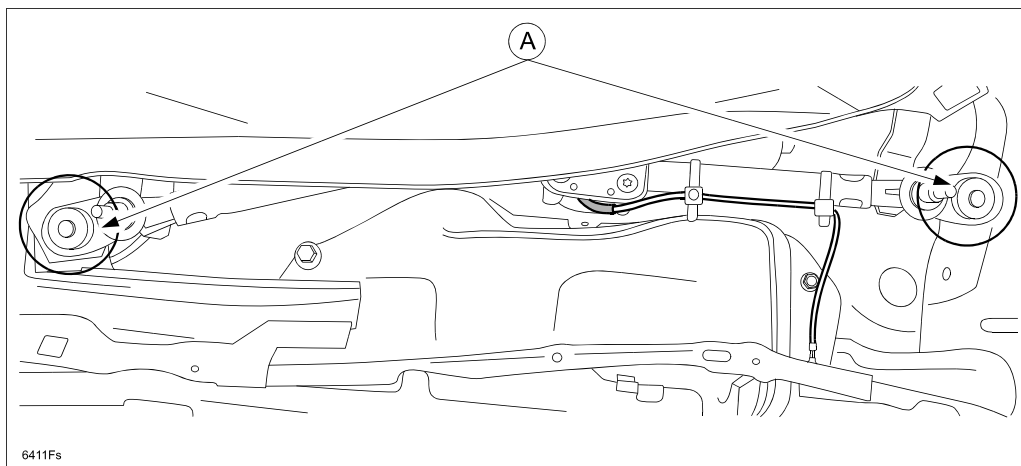

10. Check the routing of the harness, then tighten the two tie wraps and cut the extra portion of the tie wraps (A).

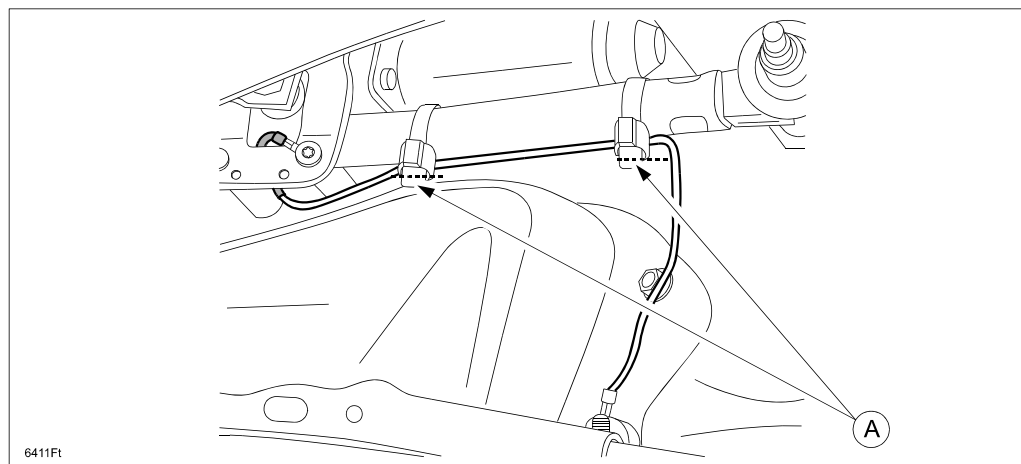

CONFIRMATION OF GROUND HARNESS INSTALLATION AND REPAIR COMPLETION

1. Verify that there is no interference to the ground harness or tie wraps.
 - Insert the key into the ignition.
 - Turn the ignition ON, then activate the wipers.
 - Make sure nothing is touching the ground harness or tie wraps.
 - Turn the wipers OFF.
 - Turn the ignition OFF.
2. Reinstall the parts in the reverse order of removal.
 - Clean the windshield wiper arm connecting shafts using a wire brush before installing the windshield wiper arms. Use locator marks as a reference.

Tightening Torque for Wiper Arm Nut: 16-19 N·m {1.7-1.9kgf·m, 12-14 ft·lbf}

- Make sure the windshield wiper arms are adjusted properly.
 - Operate the windshield wipers, then turn them off to set the wipers in the park position.
 - Adjust the windshield wiper arm connector shafts to set the arm heights (A: Molding end line, B: Cowl grille end line).

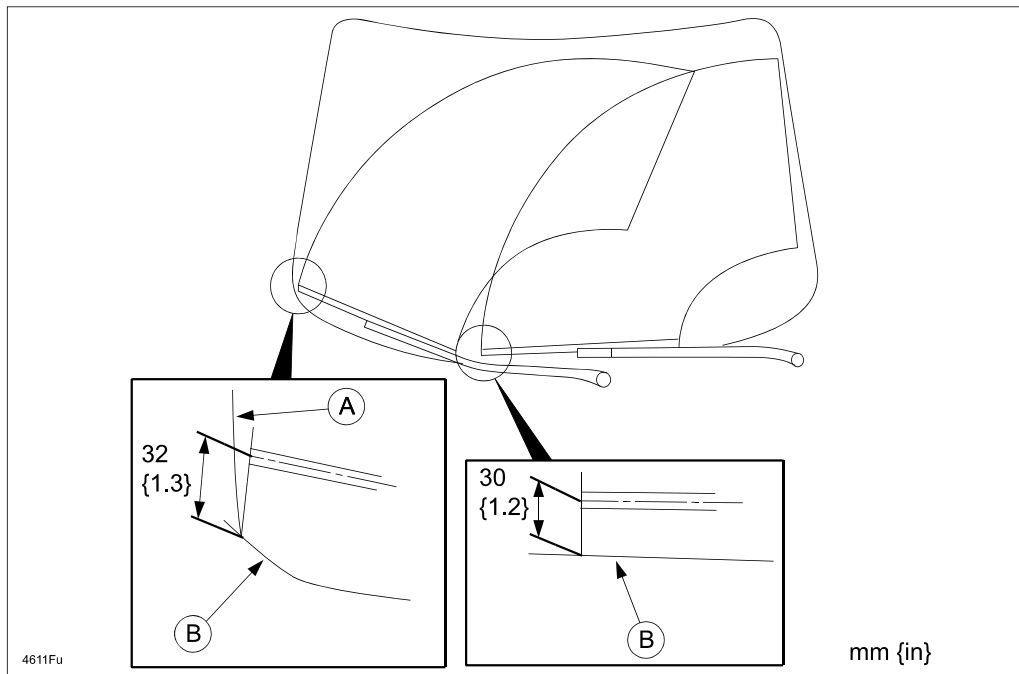

D. CAMPAIGN LABEL INSTALLATION

1. Fill out a blue "Campaign Label" (9999-95-065A-06) with Campaign No: "6411F", your dealer code, today's date.

CAMPAIGN LABEL

CAMPAIGN NO: _____

DEALER CODE: _____

DATE: / /

P/N 9999-95-065A-06

1326b

2. Affix it to the hood or bulkhead as shown:

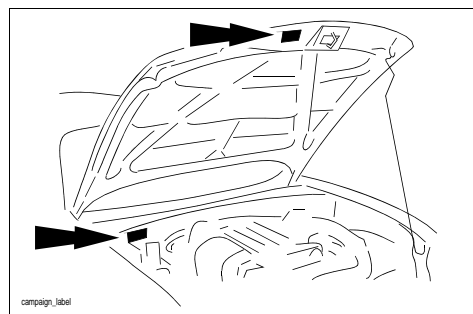

3. Return the vehicle to the customer.