



Recall Start March 1989

**Automatic Shoulder Belt
Recall Campaign [72803]
Door Latch Switch [SSP31]**

**1990-1994 323
1992-1993 MX-3
1990-1993 Protege**

TO: All **Mazda** Dealers

ATTENTION: All General Managers, Service Managers, and Parts Managers

SUBJECT: **Recall Campaign 72803 & Special Service Program – SSP31**
1990 – 1994 323, 1992 – 1993 MX-3 and 1990 – 1993 Protege

Dear **Mazda** Dealer:

Mazda Motor Corporation has decided to conduct a recall campaign for the automatic shoulder belt on 1990-1994 323 and 1992-1993 MX-3 models. In addition, **Mazda** has decided to conduct a Special Service Program to extend the warranty coverage for the front door latch switch to 12 years on 1990-1993 323, 1992-1993 MX-3 and 1990-1993 Protege models.

Mazda has determined that, under certain conditions, the cable that retracts the automatic shoulder belt buckle may bind due to excessive wear of automatic shoulder belt rail. If binding of the cable occurs, the passive restraint system is rendered inoperative.

Additionally, **Mazda** detected that, under certain conditions, the passive shoulder belt buckle may stay at the rearmost position even if the door is opened. This occurs as the grease, on the contact point of the front door latch switch, degrades over time.

Detailed information regarding these campaigns is provided in Attachment I, the repair procedures are shown in Attachment II, and the owner notifications are Attachment III.

The National Traffic and Motor Vehicle Safety Act prohibits selling or leasing any subject vehicles without performing the necessary repair for defects or failures. Failure to perform applicable recalls before sale can result in extensive fines and penalties from the Federal Government. Therefore, you must complete this recall for all affected new and used vehicles in your inventory prior to sale or lease.

Please make certain that the appropriate personnel in your dealership are familiar with the details of this recall campaign before responding to customer inquiries. Should you have any questions please contact the **Warranty Hotline at (800)-662-6779**.

We apologize for any inconvenience that this program may cause you and your customers. Your understanding and support in carrying out this campaign is greatly appreciated.

Sincerely,

MAZDA NORTH AMERICAN OPERATIONS

CONDITION OF CONCERN

[Recall 72803 - Automatic Shoulder Belt]

The cable that retracts the automatic shoulder belt buckle may bind due to dust entering the automatic shoulder belt rail causing excessive wear. If binding of the cable occurs, the passive restraint system is rendered inoperative.

[SSP31 - Door Latch Switch]

The passive shoulder belt buckle may stay at the rearmost position even if the door is opened. This occurs as the grease, on the contact point of the front door latch switch, degrades over time.

SUBJECT VEHICLES

[Recall 72803 - Automatic Shoulder Belt]

Model Year & Model	VIN Range	Comment
90-93 323	JM1BG232*L0100122 - JM1BG232*P0651901 JM1BG234*P0550052 - JM1BG234*P0651919	Door Switch SSP Is also applicable
92-93 MX-3	JM1EC431*N0100043 - JM1EC431*P0238507 JM1EC432*N0100039 - JM1EC432*PO238498	Door Switch SSP Is also applicable
94 323	JM1BG232*RO700040 - JM1BG232*RO816066 JM1BG234*RO700124 - JM1BG234*RO817583	Automatic Belt Recall only

* can be any number pr the letter "X"

[SSP31 - Door Latch Switch]

Model Year & Model	VIN Range	Comment
90-93 323	JM1BG232*L0100122 - JM1BG232*P0651901 JM1BG234*P0550052 - JM1BG234*PO651919	Automatic Belt Recall is also applicable
92-93 MX-3	JM1EC431*N0100043 - JM1EC431*P0238507 JM1EC432*N0100039 - JM1EC432*P0238498	Automatic Belt Recall is also applicable
90-93 Protege	JM1BG224*L0100065 - JM1BG224*P0655946 JM1BG226*L0100703 - JM1BG226*P0655936 JM1BG228*L0 22894 - JM1BG228*M0248937	Door Latch Switch SSP only

* can be any letter or number

OWNER NOTIFICATION

Mazda will notify subject vehicle owners in three phases, taking into account the availability of replacement parts, as follows.

	Subject Model & Campaign Contents	Kick-off Timing
1 st	1990 323 Automatic Belt and Door Latch Switch	The week of March 30
2 nd	1991 -1993 323 Automatic Belt and Door Latch Switch 1994 323 Automatic Belt only 1992-1993 MX-3 Automatic Belt and Door Latch Switch	End of May
3 rd	1990-1993 Protege Door Latch Switch only	Middle of June

PARTS INFORMATION

[Recall 72803 - Passive Shoulder Belt]

Year & Model	Part Number	Part Name	Side	Quantity
90-94 323	BRY3-57 930	Rail & Motor Assembly	RH	1
	BRY3 57 990		LH	1
	BRY4 57 93Y	Rail Assembly	RH	1
	BRY4 57 99Y		LR	1
92-93 MX-3	EAY1 57 930	Rail & Motor Assembly	RH	1
	EAY1 57 990		LH	1
	EAY2 57 93Y	Rail Assembly	RH	1
	EAY2 57 99Y		LR	1
	9999-95-065A-00	Authorized Modification Label		1

[SSP31 - Door Latch Switch]

Year & Model	Part Number	VIN/Serial Number	Side	Quantity
90-93 323	BRY5 58 314	Before L0165776	RH	1
	BRY5 59 314		LH	1
	BRY6 58 314	After L0165777	RH	1
	BRY6 59 314		LR	1
92-93 MX-3	EAY1 58314	All	RH	1
	EAY1 59314		LH	1
90-93 Protege	BRY1 58 314	Before L0165776	RH	1
	BRY1 59 314		LH	1
	BRY2 58 314	After L0165777	RH	1
	BRY2 59 314		LR	1
All	BRY1 58 317	Silicon Sealer	Both	1
	9999-95-065A-00	Authorized Modification Label		1

Please confirm that parts are in stock at the time a customer makes an appointment to have these campaigns performed.

Authorized Modification labels are supplied at no-charge and are available in 8 1/2" X 11" sheets containing 18 labels. Please use MStore for ordering additional labels. . Applicable part number is **9999-95-065A-00**.

The inspection tool is the same as used in Recall #68702 (RX-7 Automatic Shoulder Belt). One additional tool has been included with this bulletin. However, if you need additional tools they may be ordered via MStore. Please use part number **9999-95-R728-03** for ordering.

Mazda will drop ship repair parts to dealers for 1st campaign of 90MY 323, based on the number of the subject vehicles in their assigned market area, the week of March 30.

REPAIR PROCEDURES

Refer to Attachment II.

CUSTOMER REIMBURSEMENT

Owners of subjected vehicles who have paid for the replacement of their front door latch switches and/or their automatic shoulder belts, prior to these campaigns, are eligible for reimbursement under the guidelines set forth on the Reimbursement Application Form. All applications for reimbursement must be submitted to **Mazda North American Operations**.

WARRANTY EXTENTION

[Recall 72803 - Automatic Shoulder Belt]

The warranty coverage for the automatic shoulder belt rail and motor on subject vehicles has been extended over the lifetime of the vehicle.

[SSP31 - Door Latch Switch]

The warranty period for the front door latch switches on subject vehicles has been extended to 12 years, unlimited mileage from the original warranty start date.

APPLICABLE PARTS FOR LIFETIME WARRANTY.

[Recall 72803 - Automatic Shoulder Belt]

Model	Part Number	Part Name	Side
323	BRY3 57 930	Rail & Motor Assembly	RH
	BRY3 57 990		LH
	BRY4 57 93Y	Rail Assembly	RH
	BRY4 57 99Y		LR
MX-3	EAY1 57 930	Rail & Motor Assembly	RH
	EAY1 57 990		LH
	EAY2 57 93Y	Rail Assembly	RH
	EAY2 57 99Y		LR

Applicable parts for 12 years warranty period extension from warranty start date.

[SSP31 - Door Latch Switch]

Model Year & Model	Part Number	VIN Serial #	Side
90-93	BRY5 58 314	Before L0165776	RH
	BRY5 59 314	Before L0165776	LH
323	BRY6 58 314	After L0165777	RH
	BRY6 59 314	After L0165777	LH
92-93	EAY1 58 314	Any	RH
	EAY1 59314	Any	LH
90-93 Protege	BRY1 58314	Before L0165776	RH
	BRY1 59 314	Before L0165776	LH
	BRY2 58 314	After L0165777	RH
	BRY 259 314	After L0165777	LH

WARRANTY INFORMATION FOR RECALL 72803 - AUTOMATIC SHOULDER BELT

Applicable Model: 90-94 323	Inspection Only	Rail & Motor Replacement (Includes Inspection) *		Rail Assembly Replacement (Includes Inspection)	
	(Both sides)	(One side)	(Both sides)	(One side)	(Both sides)
Process Number	A8114H	A8114H	A8114H	A8114H	A8114H
Warranty Type Code	R	R	R	R	R
Symptom Code	99	99	99	99	99
Damage Code	99	99	99	99	99
Part Number Main Cause	BRY3-57-990	BRY3-57-930 or BRY3-57-990	BRY3-57-990	BRY4-57-93Y Or BRY4-57-99Y	BRY4-57-99Y
Quantity	0	1	1	1	1
Labor Operation Code	XX999XR1	XX999XR2	XX999XR3	XX999XR6	XX999XR7
Labor Hours	0.3	0.8	1.1	1.2	1.7

Use Process Number **A8114J** for Lifetime Warranty

Applicable Model: 92-93 MX-3	Inspection Only	Rail & Motor Replacement (Includes Inspection)		Rail Assembly Replacement (Include Inspection)	
	(Both sides)	(One side)	(Both sides)	(One side)	(Both sides)
Process Number	A8114H	A8114H	A8114H	A8114H	A8114H
Warranty Type Code	R	R	R	R	R
Customer Comment	99	99	99	99	99
Damage Code	99	99	99	99	99
Part Number Main Cause (PNMC)	EAY1 57 990	EAY1 57 930 Or EAY1 57 990	EAY1 57 990	EAY2 57 93Y or EAY2 57 99Y	EAY2 57 99Y
Quantity	0	1	1	1	1
Labor Operation Code	XX999XR8	XX999XR9	XX999XRA	XX999XRD	XX999XRE
Labor Hours	0.3	1.0	1.7	1.4	2.3

Use Process Number **A8114J** for Lifetime Warranty

WARRANTY INFORMATION FOR SSP31 - DOOR LATCH SWITCH

Applicable Model 90-93 Protege	Inspection Only (Buckle Operation)	Door Latch Switch Replacement (Includes Inspection)	
	(Both Sides)	(One Side)	(Both Sides)
Process Number	A8114K	A8114K	A8114K
Warranty type Code	R	R	R
Customer Comment	99	99	99
Damage Code	99	99	99
Part Number Main Cause (PNMC)	BRY1-59-314 or BRY2-59-314	BRY1-58-314, BRY1-59-314, BRY2-58-314 or BRY2-59-314	BRY1-59-314 or BRY2-59-314
Quantity	0	1	1
Labor Operation Code	XX999XRF	XX999XRG	XX999XRH
Labor Hours	0.3	0.5	1.0

Use Process Number **A8114L** for 12 Year Extended Warranty

Applicable Model: 90-93 323	Door Latch Switch Replacement (Includes Inspection)	
	(One Side)	(Both Sides)
Process Number	A8114K	A8114K
Warranty type Code	R	R
Customer Comment Code	99	99
Damage Code	99	99
Part Number Main Cause (PNMC)	BRY5-58-314, BRY5-59-314, BRY6-58-314 or	BRY5-59-314 or BRY6-59-314
Quantity	1	1
Labor Operation Code	XX999XRG	XX999XRH
Labor Hours	0.5	1.0

Use Process Number **A8114L** for 12 Year Extended Warranty

Applicable Model: 92-93 MX-3	Door Latch Switch Replacement (Includes Inspection)	
	(One Side)	(Both Sides)
Process Number	A8114K	A8114K
Warranty type Code	R	R
Customer Comment Code	99	99
Damage Code	99	99
Part Number Main Cause (PNMC)	EAY1-58-314 Or EAY1-59-314	EAY1-59-314
Quantity	1	1
Labor Operation Code	XX999XRJ	XX999XRK
Labor Hours	0.7	1.4

Use Process Number **A8114L** for 12 Year Extended Warranty

Part Number **BRY1-58-317** (Silicone Sealer) can be claimed on the first SSP31 claim. Dealers should not claim more than 1 tube of silicone for 40 claims. Claims with silicone sealer will be strictly monitored.

Repair Procedure Chart
[Recall 72802] Automatic Shoulder Belt and [SSP31] - Door Latch Switch

NOTE: Activities shown below are basic procedures. Refer to the actual instructions when performing these recall campaigns

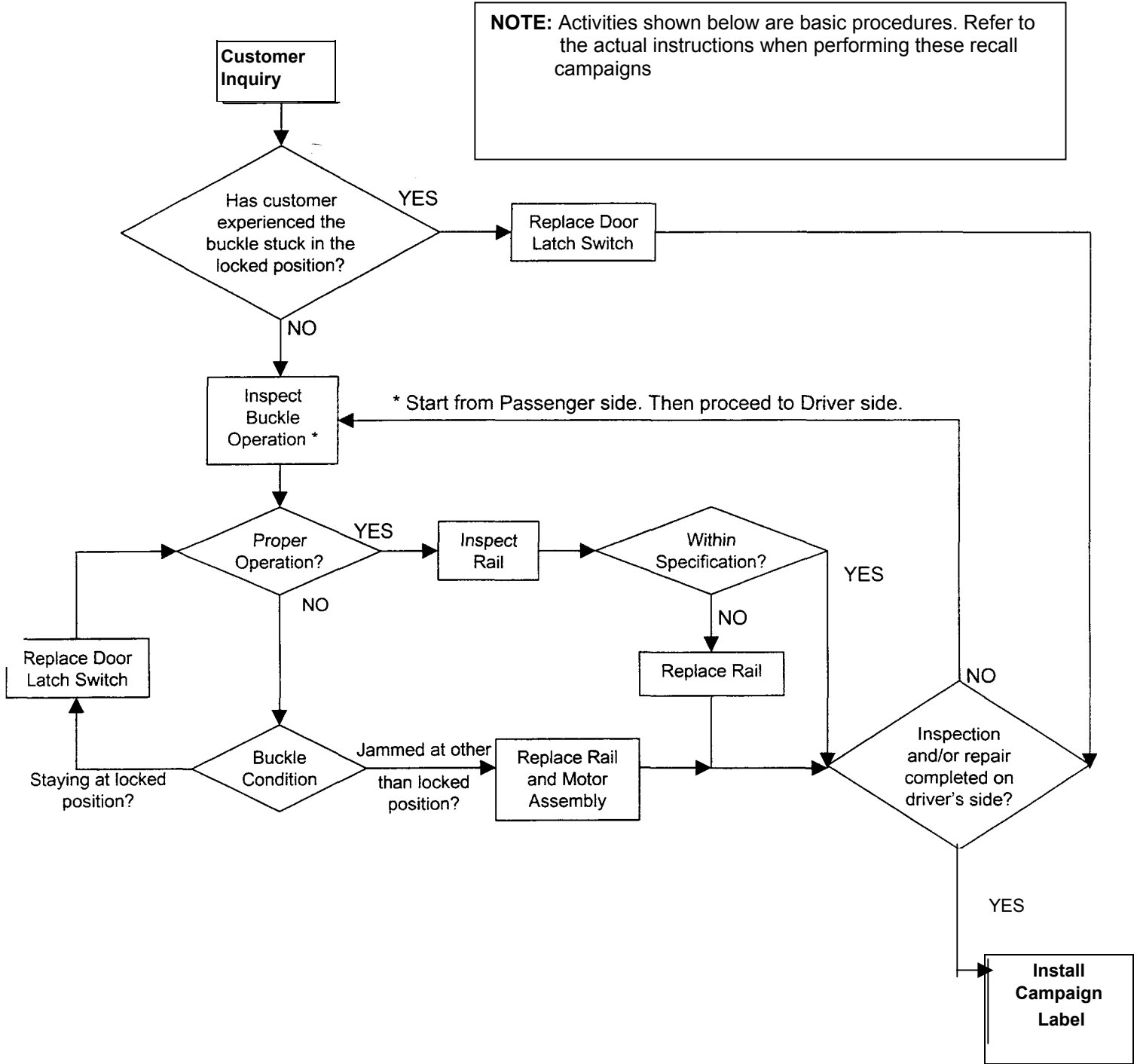

NOTE: Parts needlessly replaced will be subject to charge back. Inspection must be carried out individually on the driver side and passenger side. Do not replace the rail and motor on the Passenger side without inspection when the driver side is replaced.

Repair Procedure Chart
[Recall 72803] Automatic Shoulder

Applicable model: 94 323

NOTE: Activities shown below are basic procedures.
Refer to the actual instructions when performing these recall campaigns

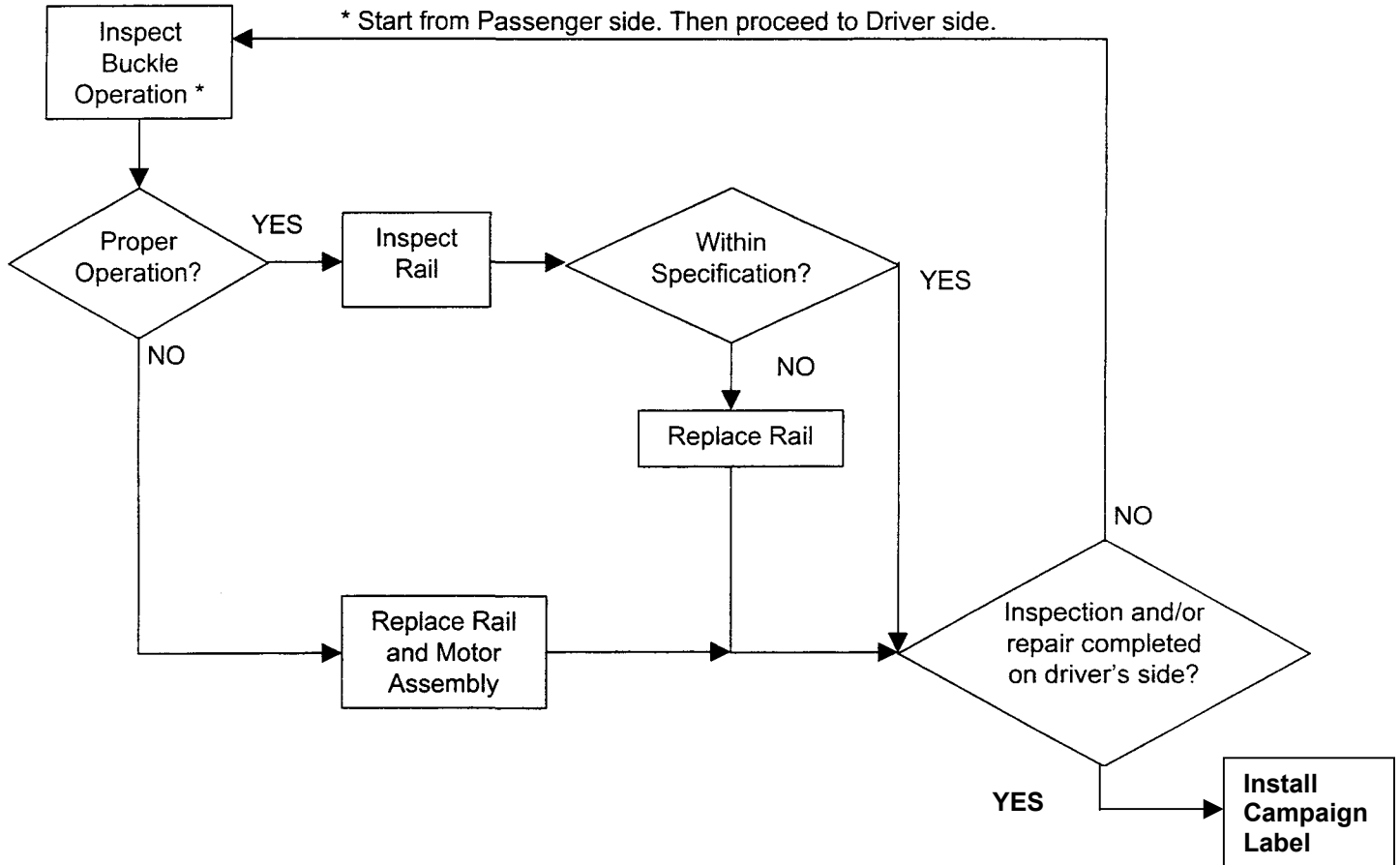

NOTE: Parts needlessly replaced will be subject to charge back. Inspection must be carried out individually on the driver side and passenger side. Do not replace the rail and motor on the Passenger side without inspection when the driver side is replaced.

Repair Procedure Chart
[SSP31] Door Latch Switch

Applicable models: 90-93 Protege

NOTE: Activities shown below are basic procedures.
Refer to the actual instructions when performing these recall campaigns

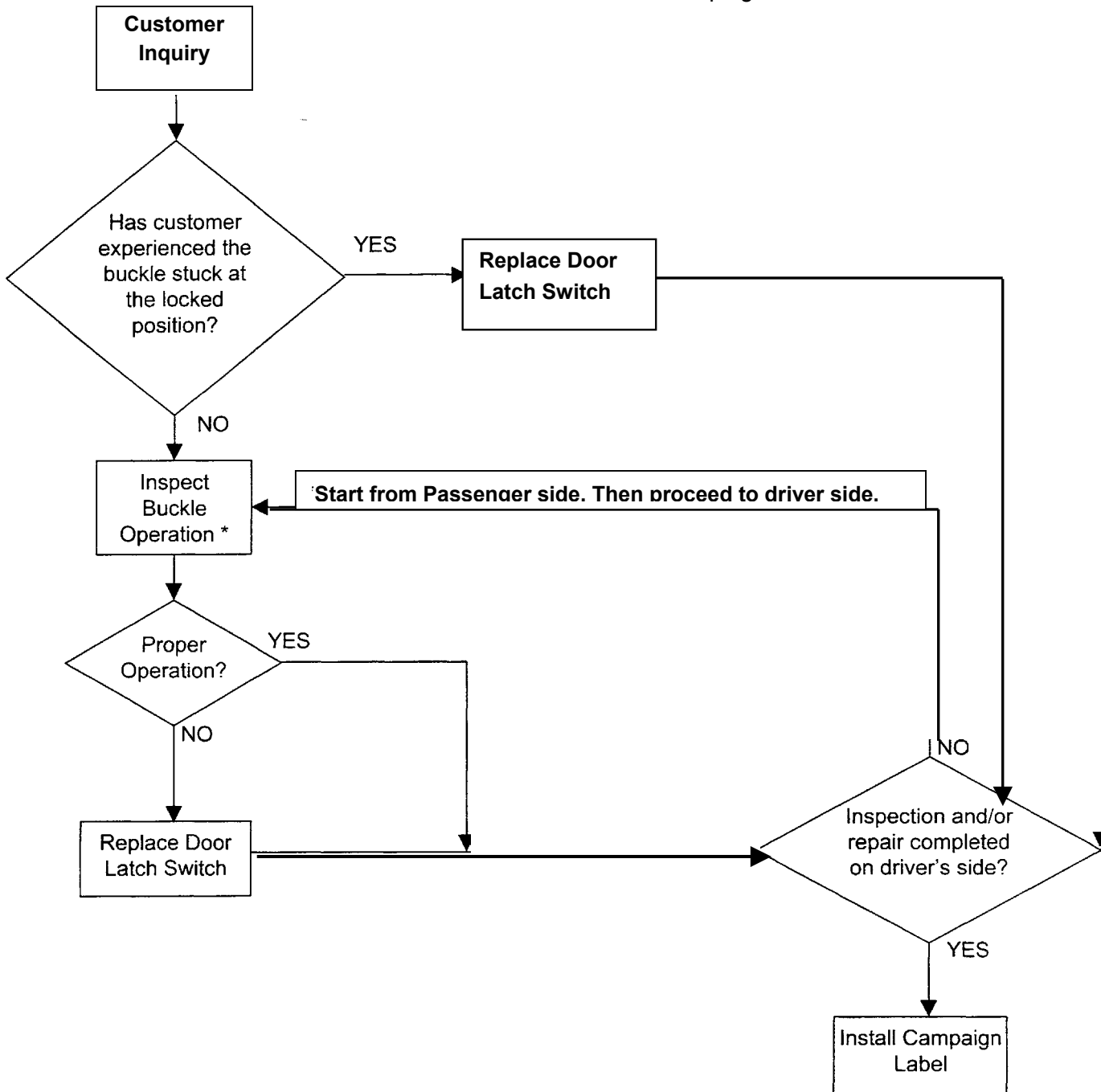

NOTE: Parts needlessly replaced will be subject to charge back
. Inspection must be carried out individually on the driver side and passenger side.

REPAIR PROCEDURE**[RECALL 72803 & SSP31] 1990-94 323/1990-93 PROTEGE/1992-93 MX-3****A. VEHICLE INSPECTION PROCEDURE**

1. Verify the VIN:

MODEL	VIN
1990-93 323	JM1 BG232*L0 100122 – P0651901 JM1 BG234*P0550052 – P0651919
1994 323	JM1 BG232*R0700040 - R0816066 JM1 BG234*R0700124 - R0817583
1992-93 MX-3	JM1 EC431*N0100043 – P0238507 JM1 EC432*N0100039 – P0238498
1990-93 Protege	JM1 BG224*L0100065 – P0655946 JM1 BG226*L0100703 – P0655936 JM1 BG228*L0122894 – M0248937

- If the vehicle is within the above range, proceed to step 2.
- If the vehicle is not within the above range, return the vehicle to the customer or inventory.

2. Perform a Vehicle Status inquiry using your **MDCS** System and inspect vehicle for an Authorized Modification Label **RECALL 72803 or SSP33** attached to the driver's side door. Refer to illustration below.

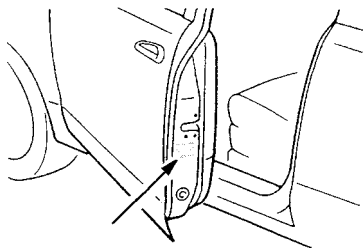

**INSPECT VEHICLE
FOR RECALL OR SSP
LABEL**

- If **MDCS** displays **RECALL 72803 or SSP33 Open** and an Authorized Modification Label is **not present**, the recall has not been performed. Proceed to "**B. CUSTOMER INQUIRY.**"
- If **MDCS** displays **RECALL 72803 or SSP33 Open** and an Authorized Modification Label is **present**, contact the **Warranty Department at (800) 662-6779**. They will update the vehicle history.
- If **MDCS** displays **RECALL 72803 or SSP33 Closed** and an Authorized Modification Label is **not present**, proceed to "**D. AUTHORIZED MODIFICATION LABEL INSTALLATION.**"
- If **MDCS** displays **RECALL 72803 or SSP33 Closed** and an Authorization Modification Label is **present**, the recall has already been completed. Return the vehicle to the customer or inventory.
- If **MDCS** does not display **RECALL 72803 or SSP33 Open** or **RECALL 72803 or SSP33 Closed**, this recall does not apply to the vehicle. Return vehicle to the customer or inventory •

B. CUSTOMER INQUIRY

Applicable Model: 1990-93323
1992-93 MX-3
1990-93 Protégé

Replace the door latch switch if a customer has experienced the buckle staying in the lock (rear-most) position after the door is opened. Proceed to "**D. DOOR LATCH SWITCH REPLACEMENT**".

Note

- This issue can be intermittent and difficult to duplicate. Therefore, it is important to ask the customer if they have experienced the belt buckle staying in the lock position after the door was opened.

C. BUCKLE OPERATION INSPECTION

1. Turn ON the ignition.
2. Check the automatic shoulder belt by opening and closing the door.

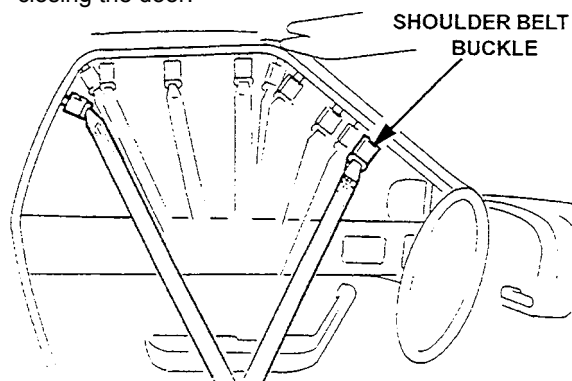
**[1990-93 323 & 1992-93 MX-3]**

- If the buckle stays in the lock (rear-most) position when the door is opened, proceed to "**D. DOOR LATCH SWITCH REPLACEMENT**".
- If the buckle is stuck other than in the lock position, proceed to "**D. RAIL & MOTOR REPLACEMENT**".
- If the buckle operates properly, proceed to "**E. RAIL INSPECTION**".

[1994 323]

- If the buckle is stuck other than in the lock position, proceed to "**E. RAIL & MOTOR REPLACEMENT**".
- If the buckle operates properly, proceed to "**E. RAIL INSPECTION**".

[1990-93 Protege]

- If the buckle stays in the lock position when the door is opened, proceed to "**D. DOOR LATCH SWITCH REPLACEMENT**".

C. DOOR LATCH SWITCH REPLACEMENT

1. Remove the door lock assembly per section S of the Workshop Manual

REPAIR PROCEDURE

[RECALL72803 & SSP31] 1990-94 323/1990-93 PROTEGE/1992-93 MX-3

2. Cut all tie-wraps holding the latch switch wiring harness to the lock assembly and make a note of their locations as shown on the following illustration.

3. Remove the protective rubber cover to the latch switch and then remove the latch switch by removing the two (2) screws illustrated below.

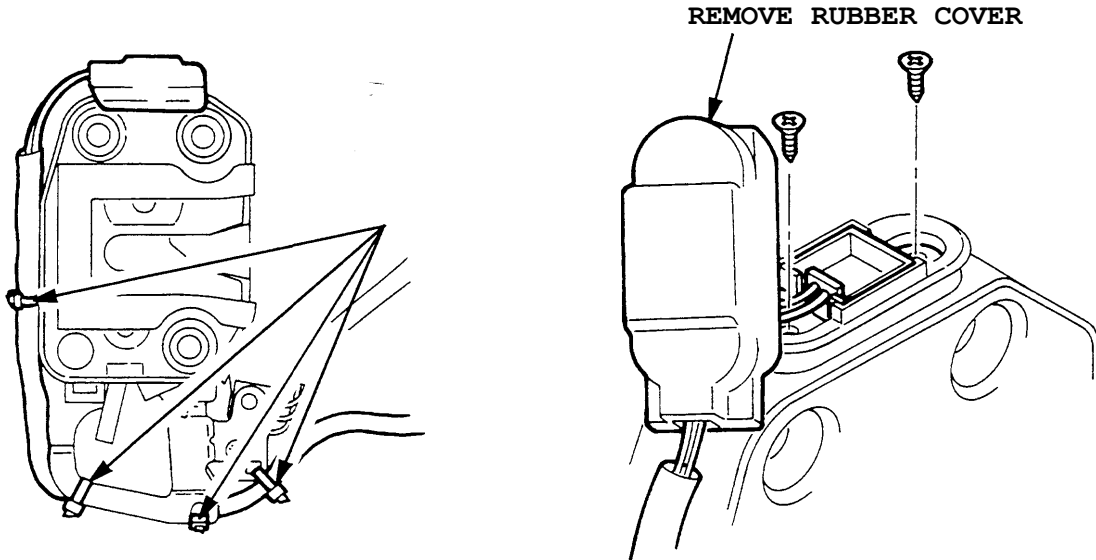

Select the applicable door latch switch using the Part Information below

PARTS INFORMATION

MODEL	SPECIFICATION	SIDE	YIN/SERIAL [^]	PART NUMBER	QTY.
323	Manual Lock	RH	Before 165776	BRY558314	1
	Manual Lock	LH	Before 165776	BRY559314	1
	Manual Lock	RH	After 165777	BRY658314	1
	Manual Lock	LH	After 165777	BRY659314	1
	Power Lock	RH	Before 165776	BRY558314	1
	Power Lock	LH	Before 165776	BRY559314	1
	Power Lock	RH	After 165777	BRY658314	1
	Power Lock	LH	After 165777	BRY659314	1
MX-3	Any	RH	Any	EAY1 58314	1
	Any	LH	Any	EAY1 58 314	1
PROTEGE	Manual Lock	RH	Before 165776	BRY1 58314	1
	Manual Lock	LH	Before 165776	BRY1 59314	1
	Manual Lock	RH	After 165777	BRY258314	1
	Manual Lock	LH	After 165777	BRY259314	1
	Power Lock	RH	Before 165776	BRY1 58314	1
	Power Lock	LH	Before 165776	BRY1 59314	1
	Power Lock	RH	After 165777	BRY258314	1
	Power Lock	LH	After 165777	BRY259314	1
ALL	Silicon Sealer	Both	Any	BRY1 58317	1

REPAIR PROCEDURE
[RECALL72803 & SSP31] 1990-94 323/1990-93 PROTEGE/1992-93 MX-3

5. Install the new latch switch onto the door lock assembly using the two (2) screws.
6. Apply silicon sealer (BRY1 58 317) to the latch where the wiring harness is soldered to the switch. This is to prevent water entry into the switch after the top rubber cover is installed.

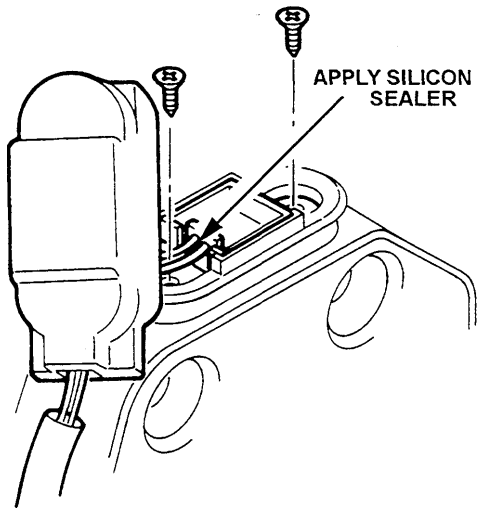

7. Secure top rubber cover over the latch switch and tie-wrap the harness back to the door lock assembly. Refer to the locations noted in the removal of the tie-wraps back in step 2.
8. Install the door lock assembly into the door per the Workshop Manual.

E. RAIL & MOTOR ASSEMBLY REPLACEMENT

1. Disconnect negative battery cable.
2. Replace the malfunctioning rail and motor assembly with the new part. Refer to section S of the Workshop Manual. See Parts Information.

PARTS INFORMATION

MODEL	PART NUMBER	PART NAME	QTY.
1990-94 323	BRY3 57 930	Rail & Motor Assy. (RH)	1
	BRY3 57 990	Rail & Motor Assy. (LH)	1
1992-93 MX-3	EAY1 57 930	Rail& Motor Assy. (RH)	1
	EAY1 57 990	Rail & Motor Assy. (LH)	1

3. Pull seaming welt back to expose body seam as illustrated.

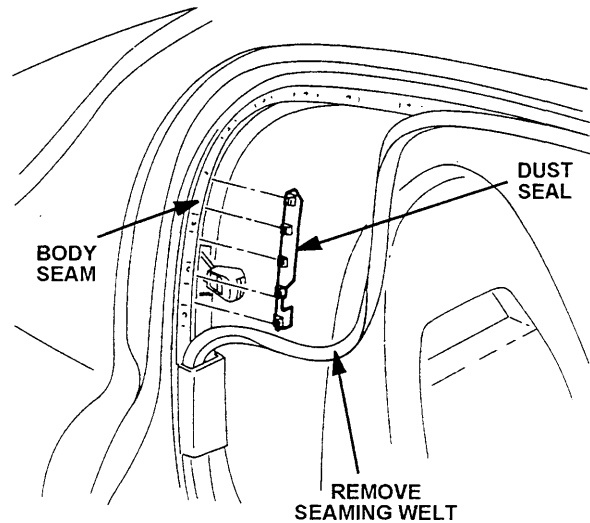

Align and clip the dust seal on the body seam as shown in the above illustration and the detail illustration below.

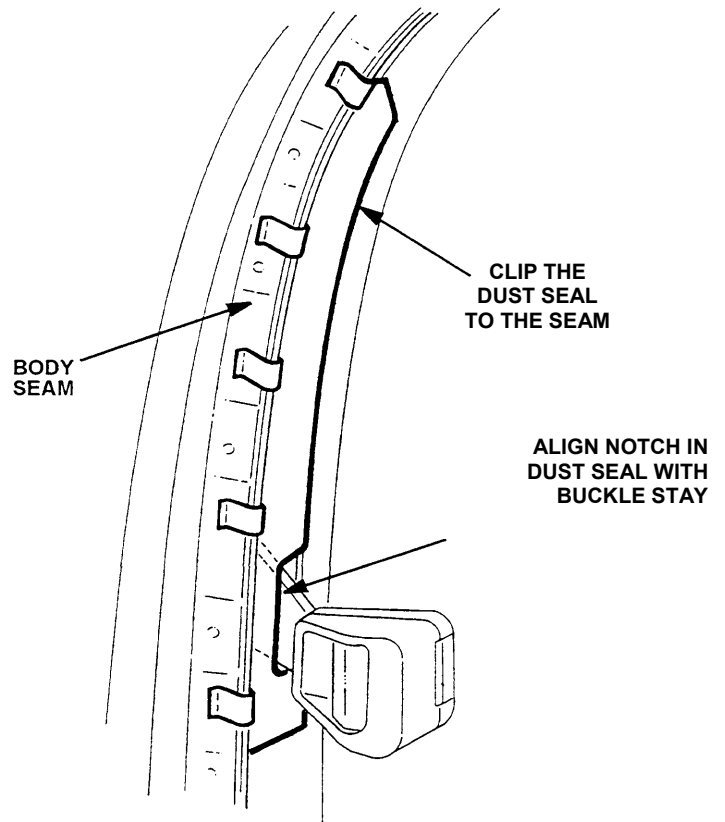

5. Re-connect the negative battery cable.
6. Confirm that the automatic shoulder belt buckle stays in the locked (rear-most) position when the door is closed.
7. Re-install seaming welt.
8. Repeat step "B. BUCKLE OPERATION INSPECTION" on the other front door if has not already been done.
9. Proceed to step "G. AUTOMATIC SHOULDER BELT OPERATION INSPECTION".

REPAIR PROCEDURE
[RECALL72803 & SSP31] 1990-94 323/1990-93 PROTEGE/1992-93 MX-3

E. RAIL INSPECTION

1. Check and record the vehicle mileage.
 2. Close the front door.
 3. Turn ON the ignition to move the automatic shoulder belt to the center pillar.
- Insert the inspection tool P/N 9999-95-R728-03 (OTC P/N T97C-61610B45-A) between the dust shields of the rail assembly at position "X" as shown below.

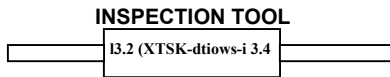

IF MILEAGE IS LESS THAN 80,000 (128,000KM), USE THE 3.2MM END OF THE INSPECTION TOOL.

IF MILEAGE IS MORE THAN 80,000 (128,000KM). USE THE 3.4MM END OF THE INSPECTION TOOL.

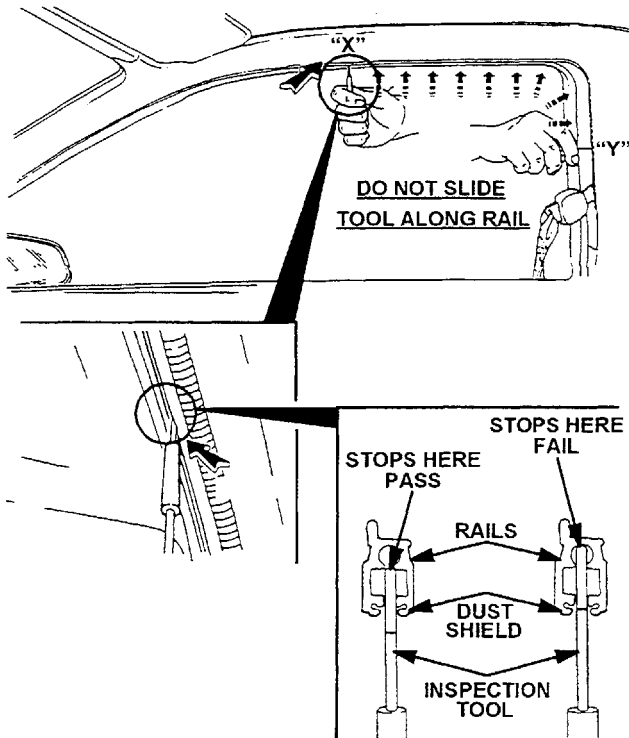

- Tool must be inserted until it stops in the rail assembly.
- Record the distance between the scribe line on the tool and dust shields.
- Insert and inspect every 1/2 inch from point "X" to point "Y" along the rail assembly.

Note

- Wear of the dust shield may cause the depth measurement distance to the scribe line to vary.

Caution

- **Do not slide the inspection tool along the shield; lubricate grease will be removed. Remove and reinsert the inspection tool every 1/2 inch.**

4. If the inspection tool's depth does not increase (tool's scribe line does not move closer to the dust shield), proceed to "C. BUCKLE OPERATION INSPECTION" for the other front door. Proceed to "H. AUTOMATIC SHOULDER BELT OPERATION INSPECTION" if the necessary inspection and repair has been completed on both sides.
- If the inspection tool's depth increases anywhere between "X" and "Y", Proceed to "G. RAIL ASSEMBLY REPLACEMENT".

G. RAIL ASSEMBLY REPLACEMENT

1. Remove the automatic shoulder belt from the vehicle. Refer to section S of the Workshop Manual.
2. Remove the rail assembly from the locking device. A. Push the dowel pin through to the outside bracket. B. Lift the plastic lever (on the locking device) with a flat screwdriver and remove the rail assembly.

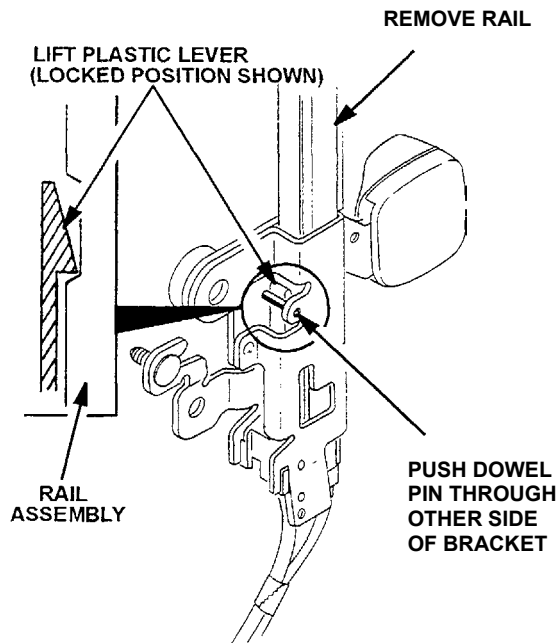

Note

- If the cable and rail assembly stick together, work the cable back and forth in the rail assembly to free the two pieces.

Insert new rail assembly into the locking device of the motor assembly.

- A. Insert the edge of the cable coming from the locking device into the rail assembly.
- B. Insert the rail assembly into the locking device.
- C. Confirm that the plastic lever is locked into the rail assembly.

REPAIR PROCEDURE
[RECALL72803 & SSP31] 1990-94 323/1990-93 ROTEGE/1992-93 MX-3

D. Install new dowel pin.

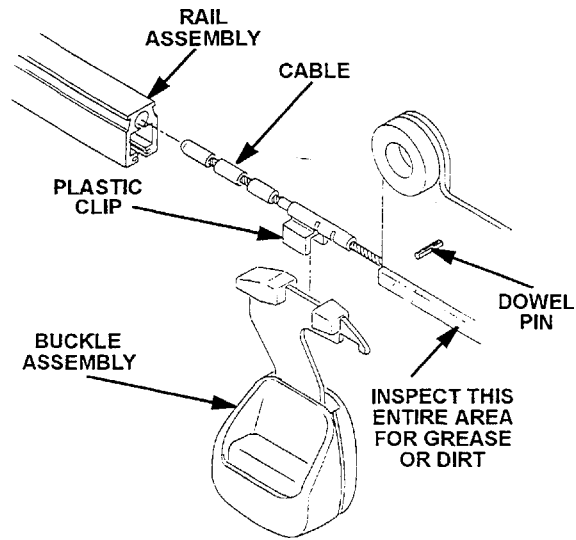

4. Install shoulder belt assembly in the vehicle.
5. Confirm that the buckle is permanently fixed in the locked position.
6. Repeat the necessary steps (starting with "C. BUCKLE OPERATION INSPECTION") on the other front door if it has not already been done.
7. Proceed to "H. AUTOMATIC SHOULDER BELT OPERATION INSPECTION".

PARTS INFORMATION

MODEL	PART NUMBER	PART NAME	QTY.
1990-94323	BRY4 57 93Y	Rail Assembly (RH)	1
	BRY4 57 99Y	Rail Assembly (LH)	1
1992-93MX-3	EAY2 57 93Y	Rail Assembly (RH)	1
	EAY2 57 99Y	Rail Assembly (LH)	1

H. AUTOMATIC SHOULDER BELT OPERATION INSPECTION

1. Turn ignition ON.
2. Close and open the door to check the automatic shoulder belt operation.
3. Repeat on other front door.

Note

- If any problems are found, repair according to the Workshop Manual.

4. Proceed to "H. CAMPAIGN LABEL ATTACHMENT".

I. AUTHORIZED MODIFICATION LABEL INSTALLATION

- Install Authorized Modification Label (recall 72803 for the automatic shoulder belt or SSP31 for the door latch switch) on the driver's side door. Refer back to the illustration under "A. VEHICLE INSPECTION PROCEDURE".