

A. VEHICLE INSPECTION PROCEDURE

1. Verify that the vehicle is within the following ranges:
 - Year Range (2007) Model (MAZDASPEED3) Produced (June 28, 2006-May 19, 2007) VIN Range (BK34**71603266-71768653)
 - If the vehicle is within the above range, proceed to step 2.
 - If the vehicle is not within the above range, return the vehicle to the customer or inventory.
2. Perform a Warranty Vehicle Inquiry using your eMDCS System and inspect vehicle for a Campaign Label **4607F** attached to the vehicle's hood or bulkhead. Refer to eMDCS System - Warranty Vehicle Inquiry Results table below.

NOTE: Verify Recall number as the vehicle may have multiple Recalls.

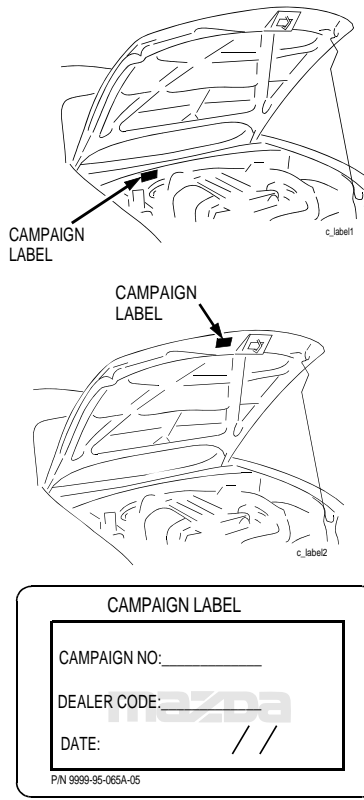

eMDCS System - Warranty Vehicle Inquiry Results

If eMDCS displays:	Campaign Label is:	Action to perform:
4607F OPEN	Present	Contact the Mazda Corporate Dealer Assistance Group at (877) 727-6626 to update vehicle history.
	Not present	Proceed to "REPAIR PROCEDURE".
4607F CLOSED	Present	Return vehicle to inventory or customer.
	Not present	Complete a label and apply to vehicle's hood or bulkhead.
4607F is not displayed	Does not apply	Recall does not apply to this vehicle. Return vehicle to inventory or customer.

B. REPAIR PROCEDURE

NO. 4 ENGINE MOUNT TIGHTENING TORQUE INSPECTION PROCEDURE

1. Record the radio presets.
2. Lift up the vehicle.
3. Remove the undercover.
4. Lower the vehicle.
5. Remove the battery cover and battery clamp.

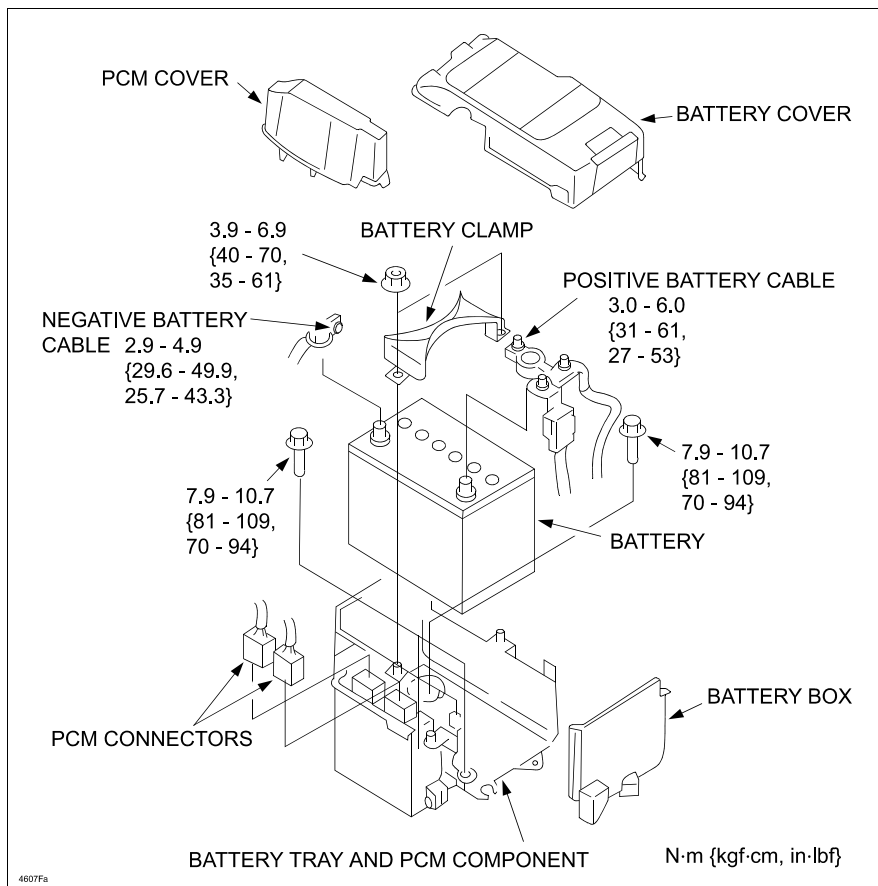

6. Disconnect the negative and positive battery cables, then remove the battery.
7. Remove the battery box.
8. Remove the PCM cover, then disconnect the connector.
9. Remove the battery tray and PCM as an assembly.

ATTACHMENT II
4607F

10. Check the torque of the No. 4 engine mount securing bolt (M14, one piece). The specified tightening torque should meet or exceed 30 N-m (3.1 kgf-m, 22.1 ft-lbf).

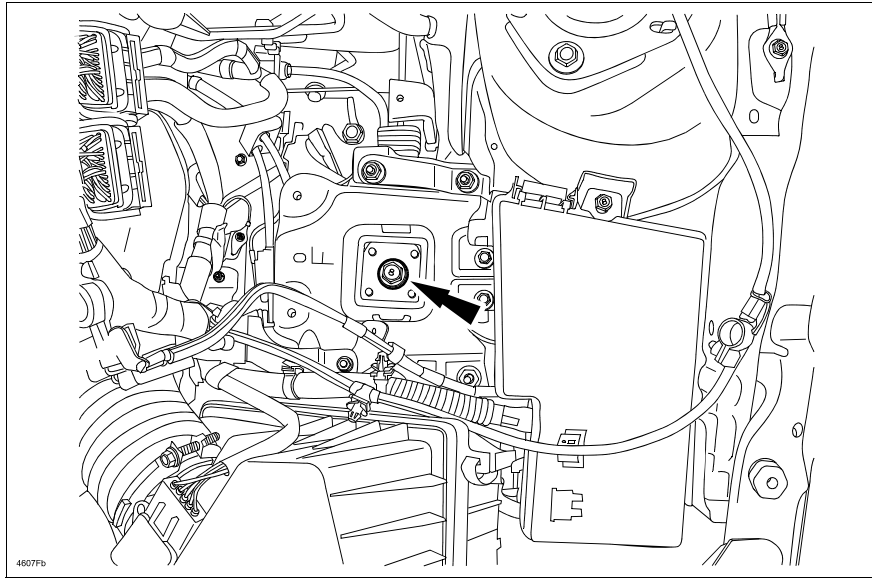

Procedure 1	VINs after JM1BK34**71708396 and bolt torqued to specified torque
Procedure 2	VINs before JM1BK34**71708397 and bolt torqued to specified torque
Procedure 3	Bolt not torqued to specified torque

PROCEDURE 1 (for vehicles produced after VIN JM1BK3471708396)**

1. Place the floor jack on the transmission case, then jack up the vehicle until the front-side height of the vehicle gets slightly higher.

NOTE: Insert a plate between the jack and transmission case in order to avoid damage on the transmission case.

Plate dimensions: 150 mm (6 inches) x 150 mm (6 inches) x 10 mm (a half inch) or more (thickness)

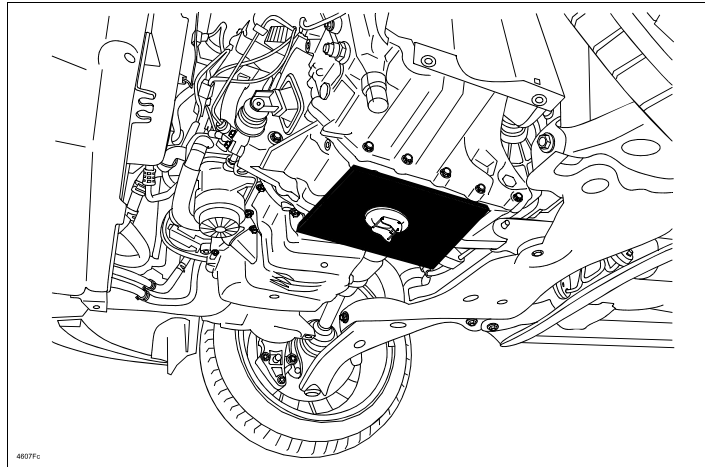

2. Using a hand tool, loosen the No. 4 engine mount securing bolt by one or two turns, then remove the bolt by hand.

NOTE: If the transmission case has not been jacked up enough, the bolt cannot be removed by hand.

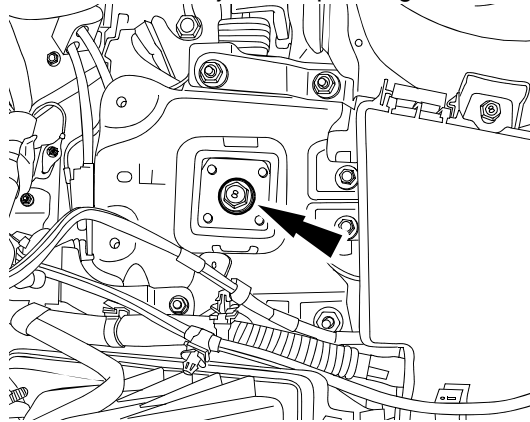

3. Insert a new No. 4 engine mount securing bolt, then temporarily tighten it by hand until the seating surface of the bolt touches the No. 4 engine mount.

NOTE:

- **To prevent cross threading be sure to start the bolt by hand.**
- If it is difficult to start the bolt, shake the engine back and forth by hand and adjust the bolt hole position.

4. Tighten the No. 4 engine mount securing bolt (M14, one piece) to the following specified torque.
Tightening torque: 129.9 – 152.7 Nm (13.3 – 15.6 kgf-cm, 95.8 – 114.8 ft-lbf)
5. Re-assemble in the reverse order of removal.
6. Set the radio presets.

PROCEDURE 2 (for vehicles produced before VIN JM1BK3471708397)**

1. Disconnect the airflow sensor connector, then loosen the air hose band.
2. Remove the air cleaner by using care of the following steps:

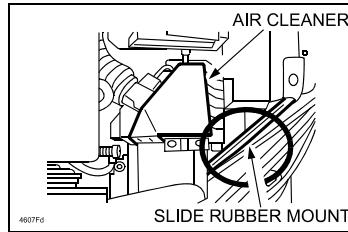

- Pull up to remove the checker tab.

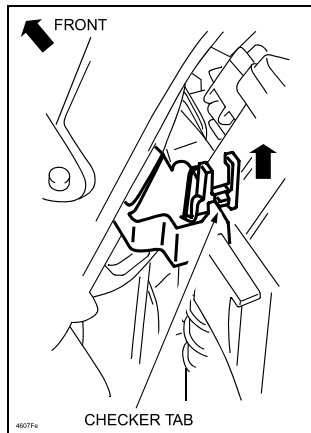

- Move the slider rubber mount backward.

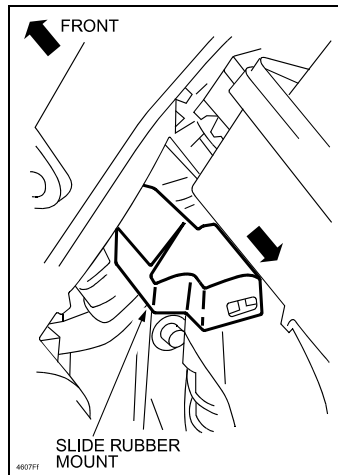

- Remove the strap.

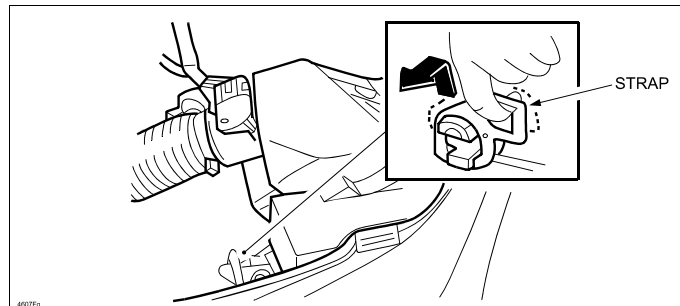

3. In order to prevent any foreign substance from entering the air hose, cover it with a shop towel.
4. Pull up the harness clip lock of the harness bracket and unlock, then move the harness toward the front-side of the vehicle and remove.

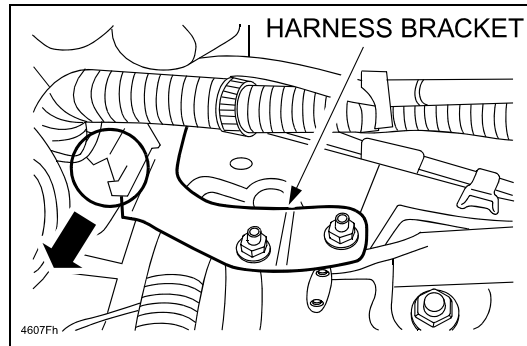

5. Remove the battery bracket bolts (M6, two pieces) and No. 4 engine mount securing nuts (M10, four pieces), then remove the battery bracket.

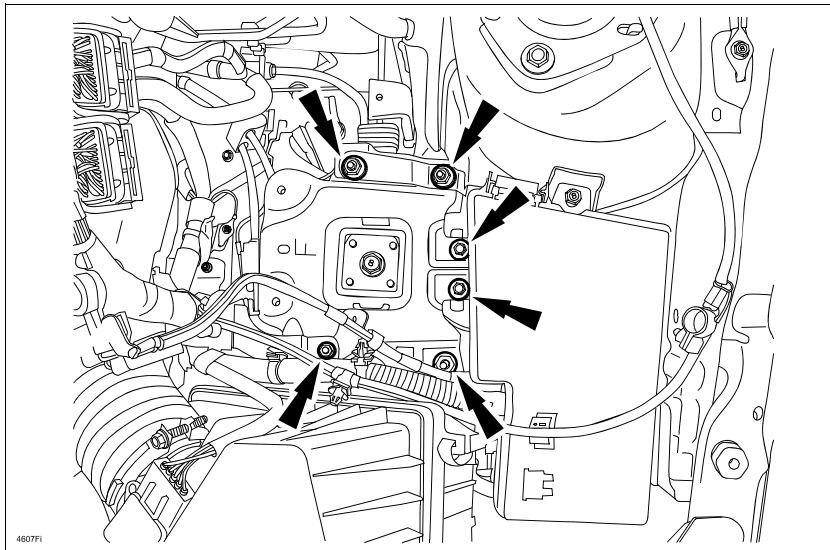

6. Place the floor jack on the transmission case, then jack up the vehicle until the front-side height of the vehicle gets slightly higher.

NOTE: Insert a plate between the jack and transmission case in order to avoid damage on the transmission case.

Plate dimensions: 150 mm (6 inches) x 150 mm (6 inches) x 10 mm (a half inch) or more (thickness)

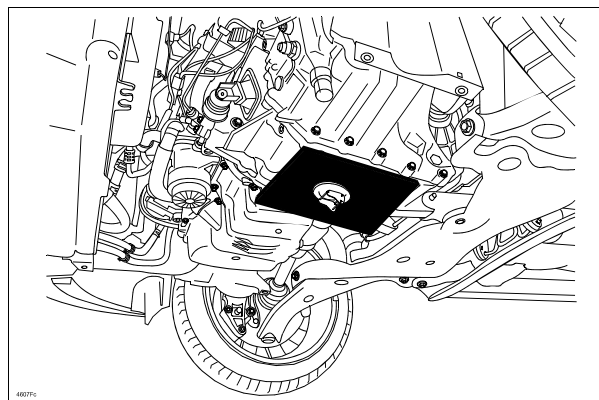

- Using a hand tool, loosen the No. 4 engine mount securing bolt by one or two turns, then remove the bolt by hand.

NOTE: If the transmission case has not been jacked up enough, the bolt cannot be removed by hand.

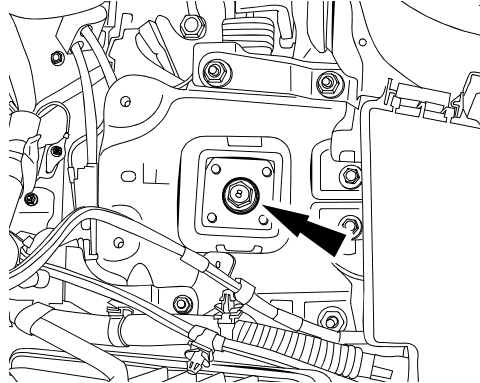

- Remove the No. 4 engine mount, then remove any rubber from the mount-to-bracket mating surface and sidewalls. As for the procedure and area of the rubber to be removed, please see the following:
 - Make a cut on the rubber on the sidewall area (four locations).

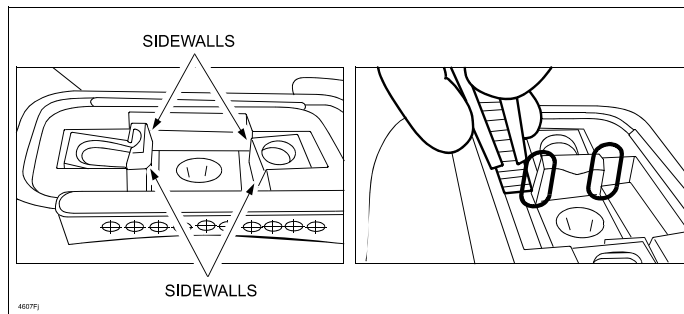

- Using a long-nose pliers, remove the rubber from the front and rear-sides sidewalls.

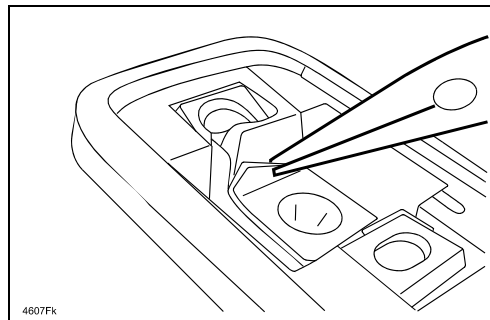

- Make sure that there is no rubber remaining on the No. 4 engine mount bracket contact surface (the surface where there is a bolt hole).

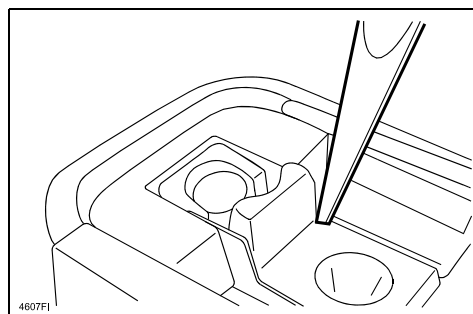

9. Reinstall the No. 4 engine mount with a new securing bolt, then temporarily tighten it by hand until the seating surface of the bolt touches the No. 4 engine mount.

CAUTION: To prevent cross threading be sure to start the bolt by hand.

NOTE: If it is difficult to start the bolt, shake the engine back and forth by hand and adjust the bolt hole position.

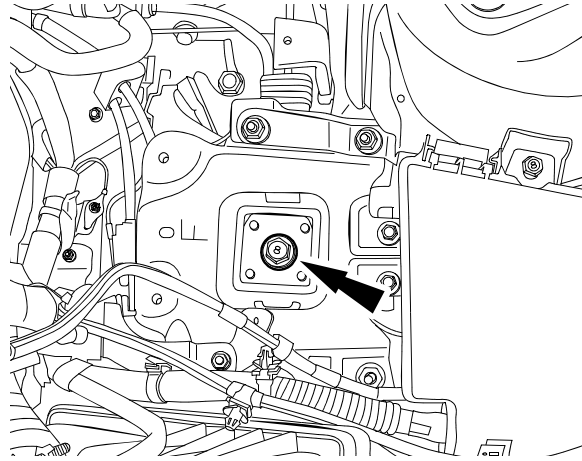

10. Lower the transmission case until the No. 4 engine mount lightly touches the body.

NOTE: Make sure of the light fitting of the No. 4 engine mount so that it can be moved by hand during No. 4 engine mount location adjustment procedure to be performed later.

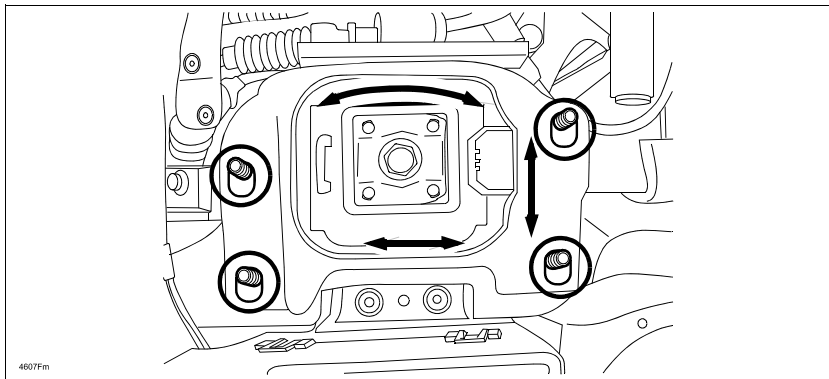

11. While moving the engine by hand, adjust so that the body-side stud bolt comes into the center of all the four holes on the No. 4 engine mount, then lower the garage jack and lower the transmission case.

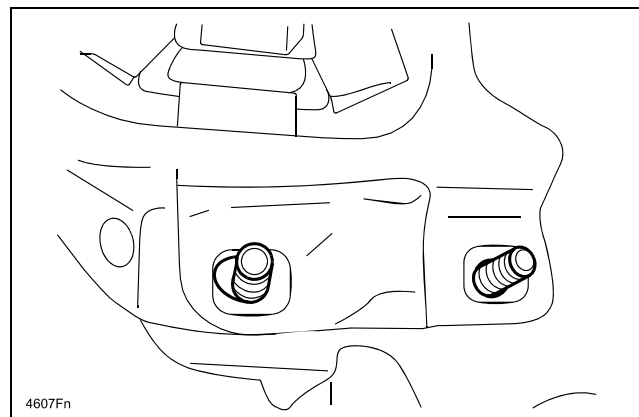

12. Re-install the battery bracket, then tighten the outer bolts (M6, two pieces) and No. 4 engine mount securing nuts (M10, four pieces).

Tightening torque: M10 (four pieces): 44.0 – 61.0 Nm (4.5 – 6.2 kgf-m, 32.5 – 44.9 ft-lbf) and M6 (two pieces): 6.9 – 9.8 Nm (70.4 – 99.9 kgf-cm, 61.1 – 86.7 in-lbf)

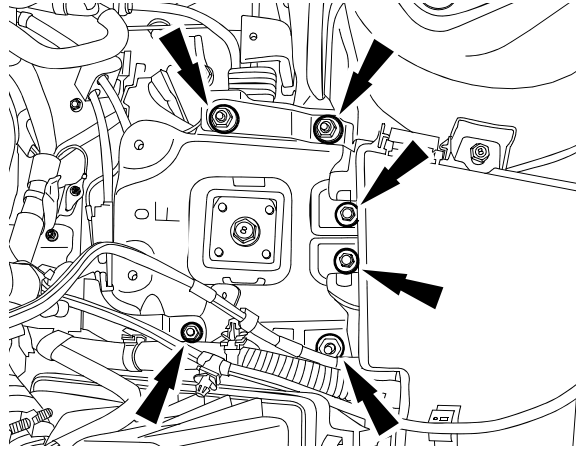

13. Tighten the No. 4 engine mount securing bolt (M14, one piece) to the following specified torque.

Tightening Torque: 129.9 – 152.7 Nm (13.3 – 15.6 kgf-cm, 95.8 – 114.8 ft-lbf)

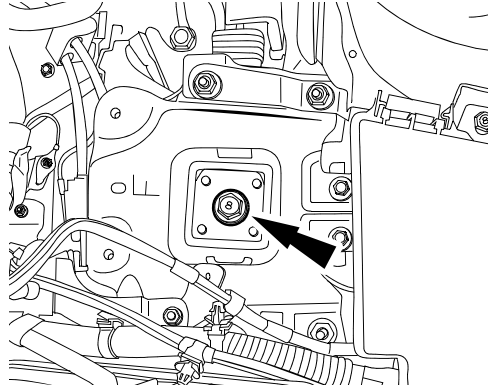

14. Re-assemble the remaining parts in the reverse order of removal.

15. Set the radio presets.

PROCEDURE 3 (for vehicles that do not reach the specified inspection torque of 30 N-m (3.1 kgf-m, 22.1 ft-lbf))

1. Refer to steps 1 – 7 of Procedure 2 to remove the No. 4 engine mount securing bolt, then remove the No. 4 engine mount.
2. Detach the pivot of the end of the shift cable by using a faster remover or equivalent tool, then pinch the cable lock and pull the cable up to remove.

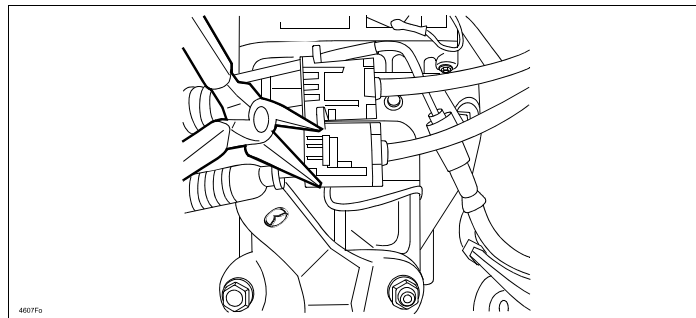

3. Remove the No. 4 engine mount bracket securing bolt (M14, three pieces), then replace the No. 4 engine mount bracket with a new one.
Tightening torque: 66.6 – 93.1 Nm (6.8 – 9.4 kgf-m, 49.2 – 68.6 ft-lbf)

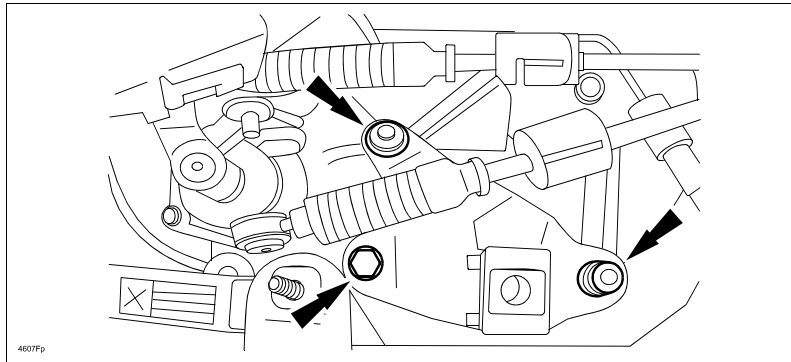

4. Refer to steps 9– 13 of Procedure 2 to install the No. 4 engine mount.
5. Re-assemble the remaining parts in the reverse order of removal.
6. Set the radio presets.

C. CAMPAIGN LABEL INSTALLATION

Complete an “Campaign Label” with the Recall number written on the sticker and affix it to the vehicle’s hood or bulkhead. Refer back to the illustration under “A. VEHICLE INSPECTION PROCEDURE”.