

Subject: MAZDA SERVICE PROGRAM (MSP30) - BLUETOOTH HANDS-FREE PHONE SYSTEM INOPERATIVE	Bulletin No: 09-038/10
	Last Issued: 08/24/2010

BULLETIN NOTE

- This bulletin supersedes the previous bulletin 09-038/10, issued on 08/11/10. The PART(S) and WARRANTY INFORMATION has been revised.
- Changes are noted below in Red beside the change bar.

APPLICABLE MODEL(S)/VINS

2010-2011 Mazda3 vehicles with VINs JM1BL****A1347511 - 354774 OR JM1BL****B1354784 - 361692 (produced from June 18, 2010 through July 16, 2010)

2010 Mazda6 vehicles with VINs 1YVHZ8C**A5M41191 - M49193 (produced from June 9, 2010 through June 25, 2010)

2010 CX-7 vehicles with VINs JM3ER****A0341534 - 342879 (produced from June 25, 2010 through July 15, 2010)

2010 CX-9 vehicles with VINs JM3TB****A0231874 - 234504 (produced from June 22, 2010 through July 14, 2010)

DESCRIPTION

On some vehicles, the "Talk", "Pick-Up" and "Hang-Up" buttons may not function.

NOTE:

- UNDER THE MAZDA SERVICE PROGRAM (MSP30), ALL CURRENT DEALER INVENTORY AND RETAILED VEHICLES FOUND TO BE WITHIN THE ABOVE VIN AND PRODUCTION DATES RANGES MUST BE REPAIRED ACCORDING TO THE INSTRUCTIONS CONTAINED IN THIS SERVICE BULLETIN.
- BEFORE PERFORMING ANY REPAIR, VALIDATE THAT THE VEHICLE IS APPLICABLE TO THIS PROGRAM BY PERFORMING AN "eMDCS WARRANTY VEHICLE INQUIRY" AND VERIFYING THE VEHICLE DISPLAYS CAMPAIGN "MSP30" AND ITS CAMPAIGN STATUS DISPLAYS "OPEN". SEE "VEHICLE INSPECTION PROCEDURE" BELOW.

DEALER INVENTORY

Repair all applicable vehicles currently in dealer inventory according to the procedures contained in this service bulletin.

RETAIL VEHICLES:

When an applicable retail vehicle is brought into the dealer for any type of repair or scheduled maintenance, perform an eMDCS Warranty Vehicle Inspection and check the status of MSP30. If status of MSP30 is "OPEN" repair the vehicle according to the procedures contained in this service bulletin.

CONSUMER NOTICE: The information and instructions in this bulletin are intended for use by skilled technicians. Mazda technicians utilize the proper tools/equipment and take training to correctly and safely maintain Mazda vehicles. These instructions should not be performed by "do-it-yourselfers." Customers should not assume this bulletin applies to their vehicle or that their vehicle will develop the described concern. To determine if the information applies, customers should contact their nearest authorized Mazda dealership. Mazda North American Operations reserves the right to alter the specifications and contents of this bulletin without obligation or advance notice. All rights reserved. No part of this bulletin may be reproduced in any form or by any means, electronic or mechanical--including photocopying and recording and the use of any kind of information storage and retrieval system ---without permission in writing.

VEHICLE INSPECTION PROCEDURE

1. Verify the vehicle is within the following VIN and production date ranges:

- 2010-2011 Mazda3 vehicles produced from June 18, 2010 through July 16, 2010
- VIN Range: JM1BL****A1347511 - 354774 OR JM1BL****B1354784 - 361692
- 2010 Mazda6 vehicles produced from June 9, 2010 through June 25, 2010
- VIN Range: 1YVHZ8C**A5M41191 - M49193
- 2010 CX-7 vehicles produced from June 25, 2010 through July 15, 2010
- VIN Range: JM3ER****A0341534 - 342879
- 2010 CX-9 vehicles produced from June 22, 2010 through July 14, 2010
- VIN Range: JM3TB****A0231874 - 234504
 - If the vehicle is within the above VIN and production date ranges, proceed to Step 2.
 - If the vehicle is not within the above VIN and production date ranges, return the vehicle to the customer or inventory.

2. Perform a Warranty Vehicle Inquiry using your eMDCS System and inspect the vehicle for a Campaign Label **MSP30** attached either to the vehicle's bulkhead or to the vehicle's hood. Refer to eMDCS System - Warranty Vehicle Inquiry Results table below.

NOTE: Verify the campaign number as the vehicle may have multiple labels.

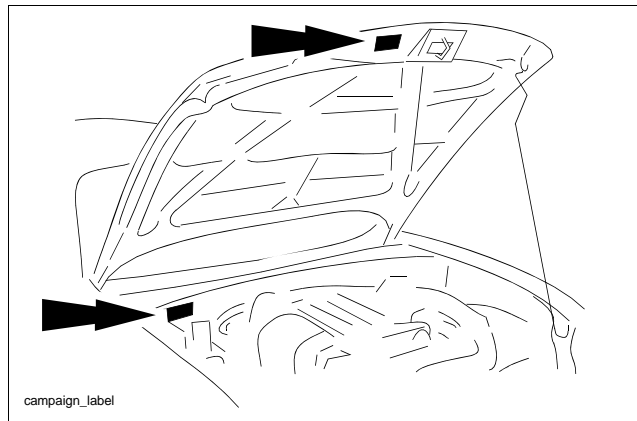

eMDCS System - Warranty Vehicle Inquiry Results

If eMDCS displays:	Campaign Label is:	Action Required:
"Campaign: MSP30 Open"	Present	Contact the Warranty Hotline at (877) 727-6626 (Option 3) to update vehicle history
	Not present	Proceed to "INSPECTION PROCEDURE"
"Campaign: MSP30 Closed"	Present	Return vehicle to inventory or customer
	Not present	Complete a label and apply it to vehicle's bulkhead or hood
"Campaign: MSP30 Open" or "Closed" is not displayed	Does not apply	Campaign does not apply to this vehicle. Return the vehicle to inventory or customer

INSPECTION PROCEDURE

NOTE: The inspection procedure differs depending on the vehicle model. Refer to the appropriate inspection procedure below.

PROCEDURE A: 2010-2011 Mazda3 / 2010 CX-7

1. Ensure the room fuse is installed.
2. Turn the ignition switch to ACC position.

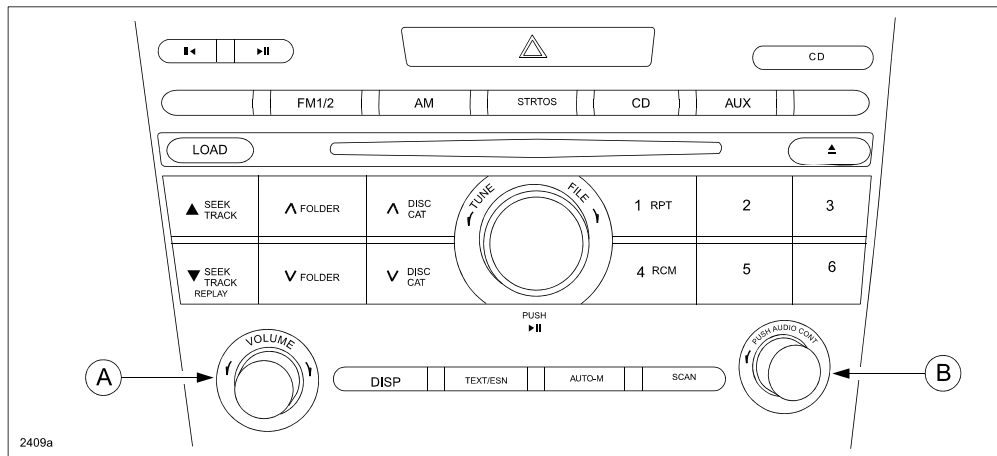

3. Turn the audio system ON (A).
4. Press the AUDIO CONT dial (B) multiple times until "BT SETUP" is displayed.
5. Turn the AUDIO CONT dial until "DEVICE INFO" is displayed.
6. Press the AUDIO CONT dial to select it.
7. The Bluetooth Address will be displayed (Example: 000A306FC11F).

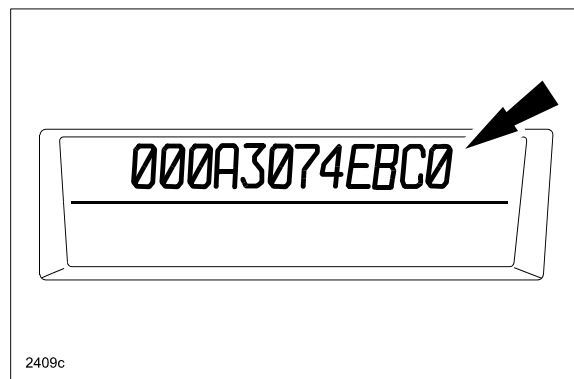

NOTE:

- If "MAZDA" is displayed, turn the AUDIO CONT dial until the Bluetooth Address appears.
 - The display will disappear in a few seconds. By turning the AUDIO CONT dial, it will remain displayed.
8. Write the Bluetooth Address on the vehicle R.O.
 9. Proceed to "BLUETOOTH MODULE CHECK" procedure.

PROCEDURE B: 2010 Mazda6 / CX-9

CX-9:

1. Open the glove box.
2. Look through the upper glove box gap to locate the Bluetooth Unit label.

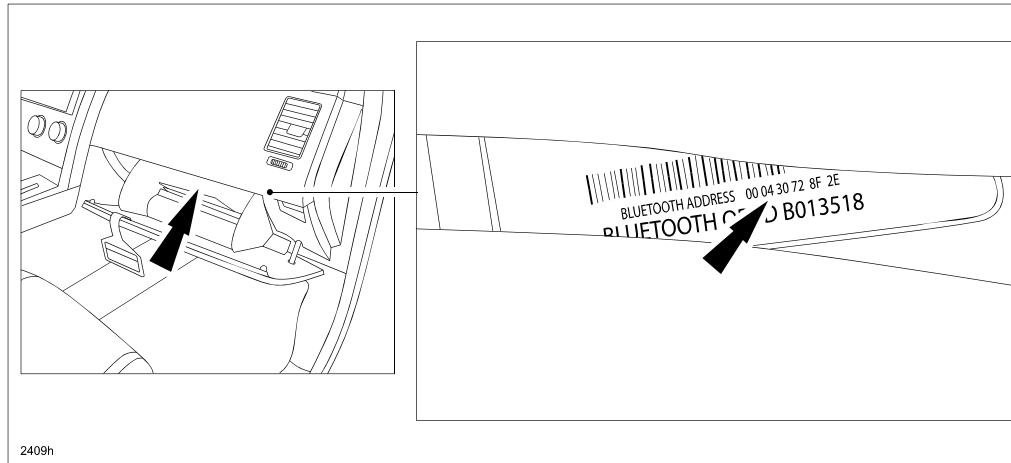

3. Write the twelve (12) digit Bluetooth Address on the vehicle R.O. (Example: 00 04 30 72 8F 2E).
4. Proceed to "BLUETOOTH MODULE CHECK" procedure.

Mazda6:

1. Remove the glove box.
2. Look through right side opening to locate the Bluetooth Unit label.

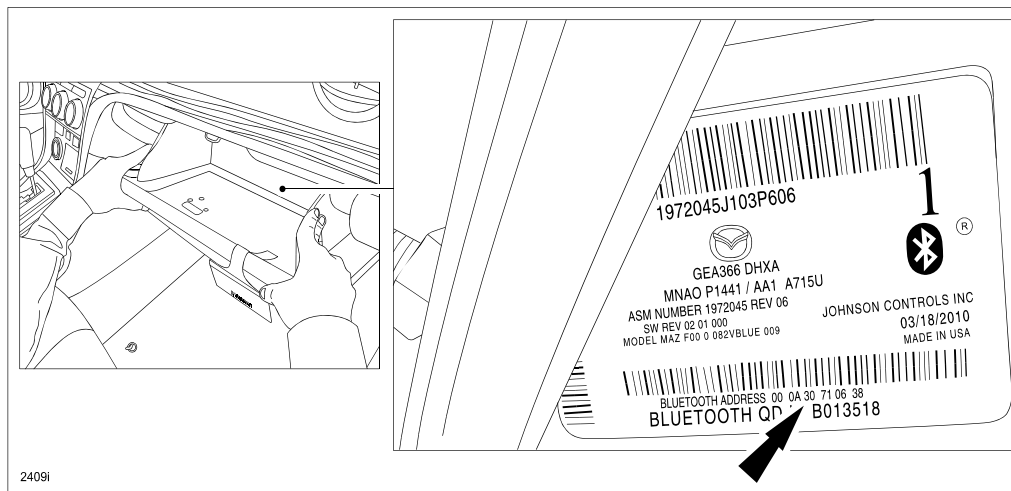

3. Write the twelve (12) digit Bluetooth Address on the vehicle R.O. (Example: 00 0A 30 71 06 38).
4. Proceed to "BLUETOOTH MODULE CHECK" procedure.

BLUETOOTH MODULE CHECK

1. Access website <http://www.mazdabtcheck.com/> to determine if the Bluetooth Unit requires replacement.

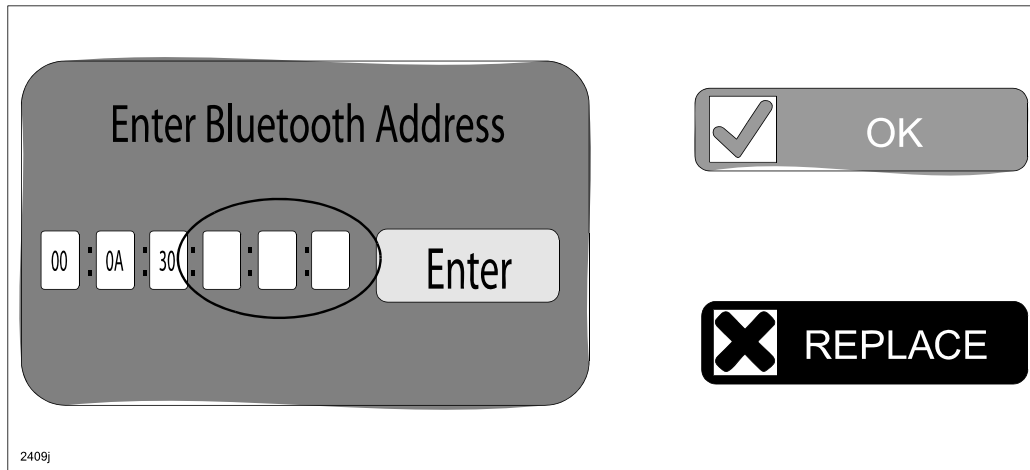

2. Enter the last six (6) digits of the Bluetooth Address, then select Enter.
 - If "OK", the Bluetooth Unit does not need to be replaced. Proceed to "CAMPAIGN LABEL".
 - If "REPLACE", the Bluetooth Unit requires replacement. Proceed to "REPAIR PROCEDURE".

NOTE: For Bluetooth Units requiring replacement, a Case Identification (ID) number will be provided by the online system. Write the Case ID on the vehicle Repair Order. The Case ID will be required to order replacement parts.

REPAIR PROCEDURE

1. Record the customer's preset radio stations.
2. Disconnect the negative battery cable.
3. Replace the Bluetooth Unit according to the Workshop Manual or MS3 online instructions:
 - 2010-2011 Mazda3: Section 09-20 BLUETOOTH UNIT REMOVAL/INSTALLATION
 - 2010 Mazda6: Section 09-20 BLUETOOTH UNIT REMOVAL/INSTALLATION
 - 2010 CX-7: Section 09-20 BLUETOOTH UNIT REMOVAL/INSTALLATION
 - 2010 CX-9: Section 09-20 BLUETOOTH UNIT REMOVAL/INSTALLATION

NOTE:

- If the new Bluetooth Unit does not include the mounting bracket, re-use the mounting bracket from the old unit. Depending on the model, tighten the mounting screws in the sequence indicated below.
- Tighten the mounting screws to the proper torque specification indicated below. All models require the same torque specifications.
- For a CX-9 Bluetooth Unit without a mounting bracket, refer to "Special Instructions For CX-9 Only".

Special Instructions For CX-9 Only: The Bluetooth Unit has a locking tab that must be released. To properly release the locking tab, insert a flat screwdriver between the bracket and the raised lip.

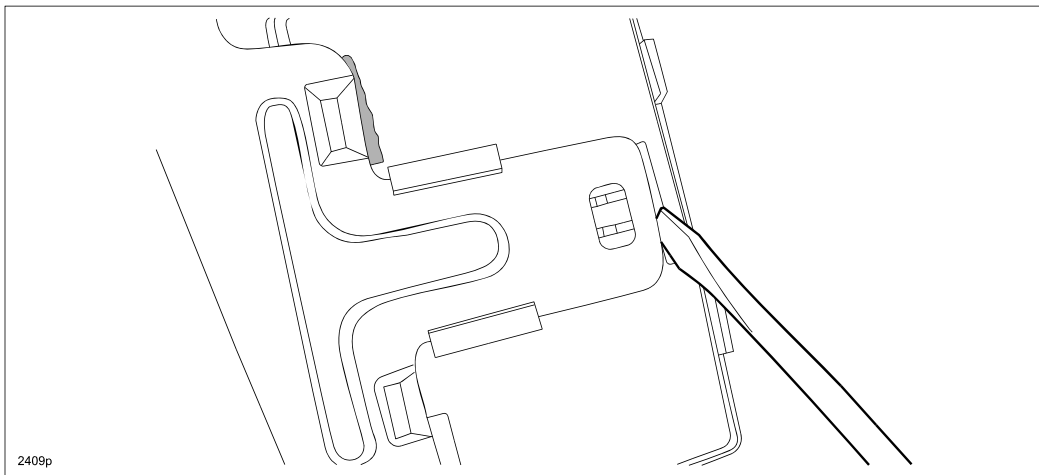

Gently twist the screwdriver to release the locking tab, then separate by hand.

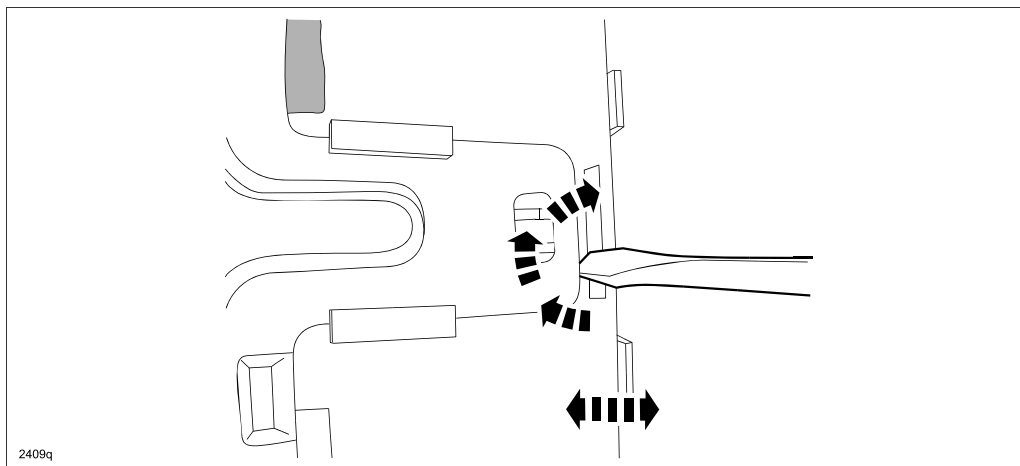

**Mounting Bracket Installation Tightening Sequence:
Tightening Torque: 1.5 - 1.9 Nm (15.4 - 20 kgf-cm, 13.5 - 17.5 in.-lbf)**

2010-2011 Mazda3:

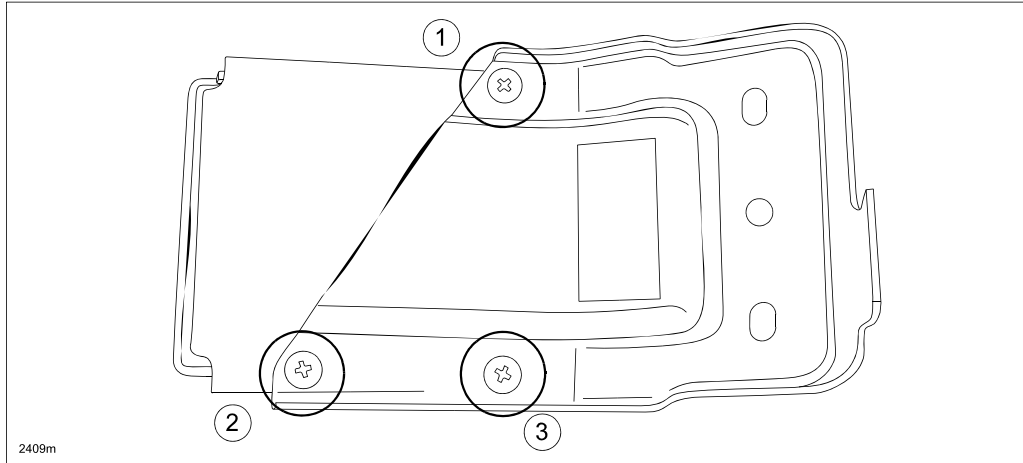

2010 Mazda6:

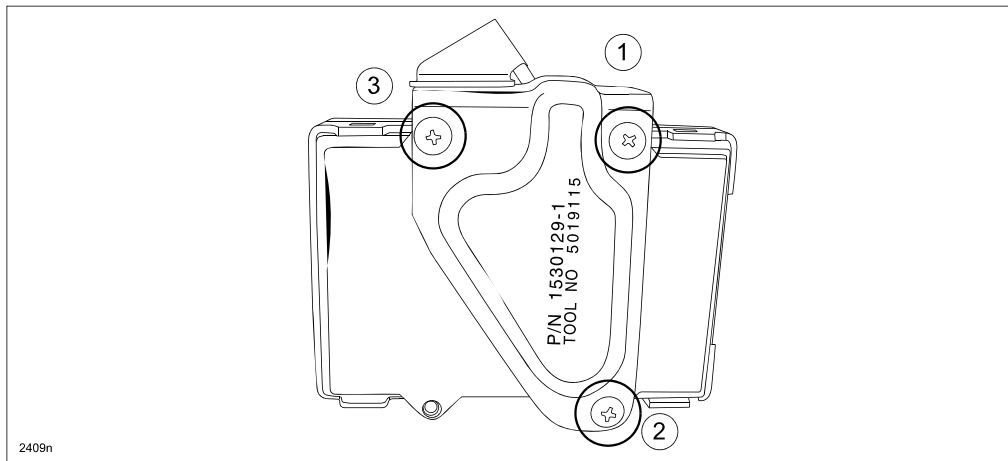

2010 CX-7:

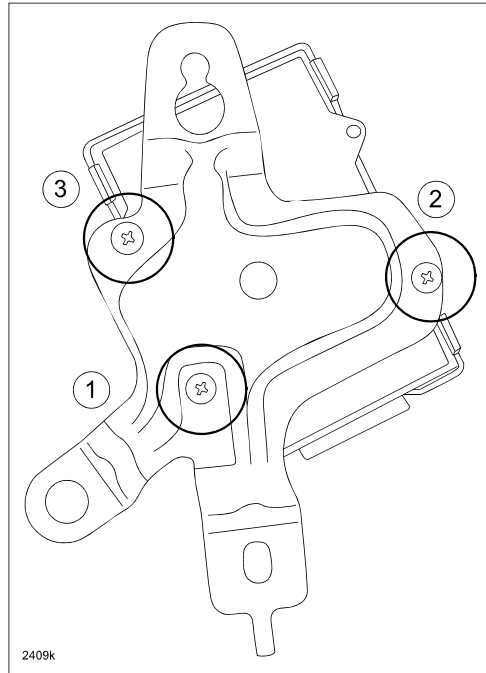

2010 CX-9:

NOTE: Screw #2 is installed and tightened **AFTER** installing the unit into the vehicle.

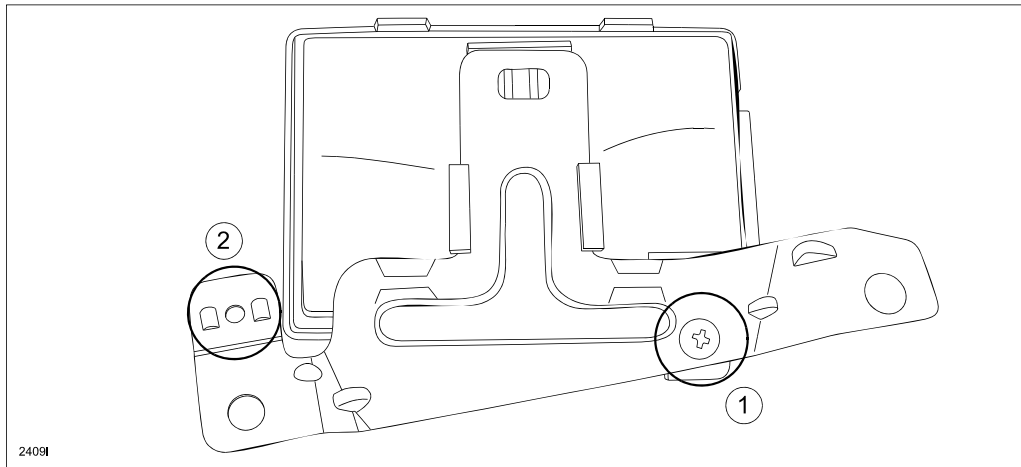

4. Re-connect the negative battery cable.
5. Turn ignition ON and wait for one (1) minute before proceeding to next step.
6. Verify the repair according to steps a~c.

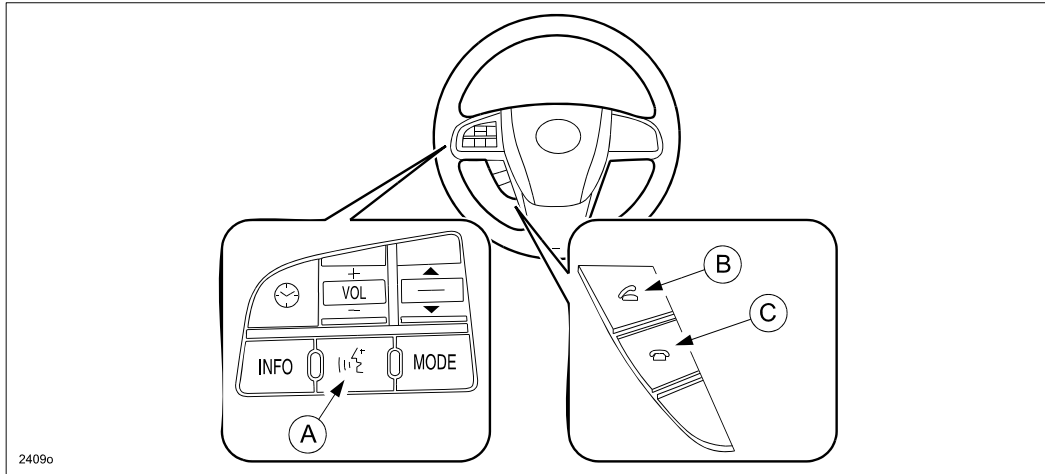

- a. Press the “Pick-Up” button (B) and confirm that a beep sound is heard.
 - b. Press the “Talk” button (A) and confirm that voice guidance is heard.
 - c. Press the “Hang-Up” button (C) to exit.
7. Re-enter the customer’s preset radio stations.
 8. Proceed to “CAMPAIGN LABEL”.

CAMPAIGN LABEL:

1. Fill out a blue “Campaign Label” (9999-95-065A-06) with the Campaign No: “MSP30”, your dealer code, today’s date, and affix it to the vehicle’s bulkhead or hood.

CAMPAIGN LABEL	
CAMPAIGN NO:	_____
DEALER CODE:	_____
DATE:	/ /

P/N 9999-95-065A-06

1326b

2. Return the vehicle to the customer or dealer inventory.

PART(S) INFORMATION

To order a new Bluetooth Unit (Adapter, Telephone), either contact United Radio by phone at 1-800-448-0944 (ask for Customer Service) or log onto the Dealer Assistance Group's "Exchange Central" on MX Connect.

When ordering a **replacement** Bluetooth Unit, be sure to have the Case Identification (ID) number (provided during the "Bluetooth Module Check") ready. The Case Identification (ID) number will be required **by United Radio** to order replacement parts.

Model Year / Model	Part Number	Description	Qty.	Notes
2010 Mazda3	BBM4-66-DHXA	Adapter, Telephone	1	---
2011 Mazda3	BBM5-66-DHX	Adapter, Telephone	1	---
2010 Mazda6	GEA3-66-DHXA	Adapter, Telephone	1	With MID 4.3" LCD audio unit
2010 Mazda6	GS3L-66-DHXF	Adapter, Telephone	1	---
2010 CX-7	EH44-66-DHX	Adapter, Telephone	1	---
2010 CX-9	TE69-66-DHXA	Adapter, Telephone	1	With streaming audio (Navigation or MID 4.3" LCD audio unit)
2010 CX-9	TD11-66-DHXD	Adapter, Telephone	1	---

WARRANTY INFORMATION

NOTE:

- This warranty information applies only to verified customer and dealer inventory vehicles eligible for warranty repair.
- This repair will be covered under Mazda's New Vehicle Limited Warranty term.
- Additional diagnostic time cannot be claimed for this repair.

INSPECTION ONLY

	Mazda3 / CX-7 / CX-9	Mazda6
Warranty Type	A	A
Symptom Code	99	99
Damage Code	99	99
Process Number	AA025B	J1005A
Part Number Main Cause	SEE PART(S) INFORMATION	SEE PART(S) INFORMATION
Quantity	0	0
Operation Number / Labor Hours	XXF3BACX / 0.2 Hrs.	YY681XRX / 0.2 Hrs.

INSPECTION AND REPLACEMENT

	CX-7	CX-9
Warranty Type	A	A
Symptom Code	99	99
Damage Code	99	99
Process Number	AA025B	AA025B
Part Number Main Cause	SEE PART(S) INFORMATION	SEE PART(S) INFORMATION
Quantity	0	0
Related Part / Qty.	5555-RE-TURN / 1	5555-RE-TURN / 1
Operation Number / Labor Hours	XXF3BCRX / 0.3 Hrs.	XXF3BCRX / 0.3 Hrs.

Bulletin No: 09-038/10
© 2010 Mazda Motor of America, Inc.

Last Issued: 08/24/2010

	Mazda3	Mazda6
Warranty Type	A	A
Symptom Code	99	99
Damage Code	99	99
Process Number	AA025B	J1005A
Part Number Main Cause	SEE PART(S) INFORMATION	SEE PART(S) INFORMATION
Quantity	0	0
Related Part / Qty.	5555-RE-TURN / 1	5555-RE-TURN / 1
Operation Number / Labor Hours	XXF3BCRX / 0.4 Hrs.	YY682XRX / 0.4 Hrs.

NOTE: Part number 5555-RE-TURN added as reimbursement of the shipping cost to return the Bluetooth core module to United Radio.