

Category 01	Applicable Models 1999-2001 PROTEGÉ (1.6 L ZM Engine)	Subject EGR VALVE SEIZED (DTC P0300, P0401)	Bulletin No. 07-46 Issued 12/08 Revised
-----------------------	---	---	---

WARRANTY EXTENSION

The warranty coverage for the EGR valve on the outlined models has been extended. The extended warranty is available for 7 years from the original warranty start date regardless of distance traveled.

APPLICABLE MODELS/VINS:

1999-2001 Protegé (1.6 L ZM Engine)

DESCRIPTION

Some vehicles may experience a rough engine idle when the vehicle is at a standstill and/or a malfunction indicator light (MIL) ON condition with diagnostic trouble codes (DTC) P0300 and/or P0401 stored in memory as a result of the EGR valve being seized.

CAUSE

Damp conditions may eventually cause the EGR valve to seize, possibly causing poor idle and/or random misfires.

REPAIR PROCEDURE

1. Verify customer concern.
2. Inspect the function of the EGR valve, using the M-MDS if necessary. If the EGR control valve is seized, replace it with a modified one according to the repair procedures outlined in the attachment.
3. Verify repair.

PARTS INFORMATION

Part Number	Description	Qty.	Notes
ZMY1 18 W00	EGR Control Valve Kit	1	Kit includes: 1 EGR valve, 10 tie-wraps, 2 clamps and 1 gasket.

CONSUMER NOTICE: Consumers should not assume this bulletin applies to their vehicle or that their vehicle will develop the described concern. To determine if the information applies, consumers should contact their nearest authorized Mazda dealership.

Number 01-07-46	Date Issued 12/07	Date Revised
------------------------	--------------------------	---------------------

CUSTOMER REIMBURSEMENTS

In the event that a customer has previously paid for the replacement of the EGR valve, and can present a copy of the customer paid Repair Order from a Mazda Dealer, clearly showing part number ZMY1-20-300 * (asterisk symbol "*" can be any letter), please reimburse the owner for the EGR valve and replacement labour only, and submit as a net item with the warranty claim. The dealer must retain a copy of the previous repair order and proof of payment, and attach to the claim.

WARRANTY INFORMATION

NOTE:

- This Warranty information only applies to verified customer complaints on vehicles eligible for warranty repair according to this bulletin.
- Additional diagnostic time cannot be claimed for this repair.
- The warranty coverage for the EGR valve on the outlined models has been extended. The extended warranty is available for 7 years from the original warranty start date regardless of distance traveled.

Warranty Type	0
Symptom Code	99
Damage Code	99
Part Number Main Cause	ZMY1 18 W00
Quantity	1
Operation Number	XXC047RX
Labour Hours	1.5 Hrs.
Coverage Period	7 years/unlimited kilometres
Net Item Code XE (Only if Customer Reimbursement Required)	All Applicable Taxes paid by Warranty System must be Backed Out of the Amount

**PLEASE COPY AND DISTRIBUTE TO ALL SERVICE PERSONNEL
MAZDA CANADA INC.
NATIONAL SERVICE DEPARTMENT
© 2007 Mazda Canada Inc.**

CONSUMER NOTICE: Consumers should not assume this bulletin applies to their vehicle or that their vehicle will develop the described concern. To determine if the information applies, consumers should contact their nearest authorized Mazda dealership.

Attachment - EGR Control Valve Stuck (DTC P0300, P0401)

Outline

After fitting the modified EGR Valve, fit the new water hoses and the new vacuum tube as shown below. The original water hose A will be discarded.

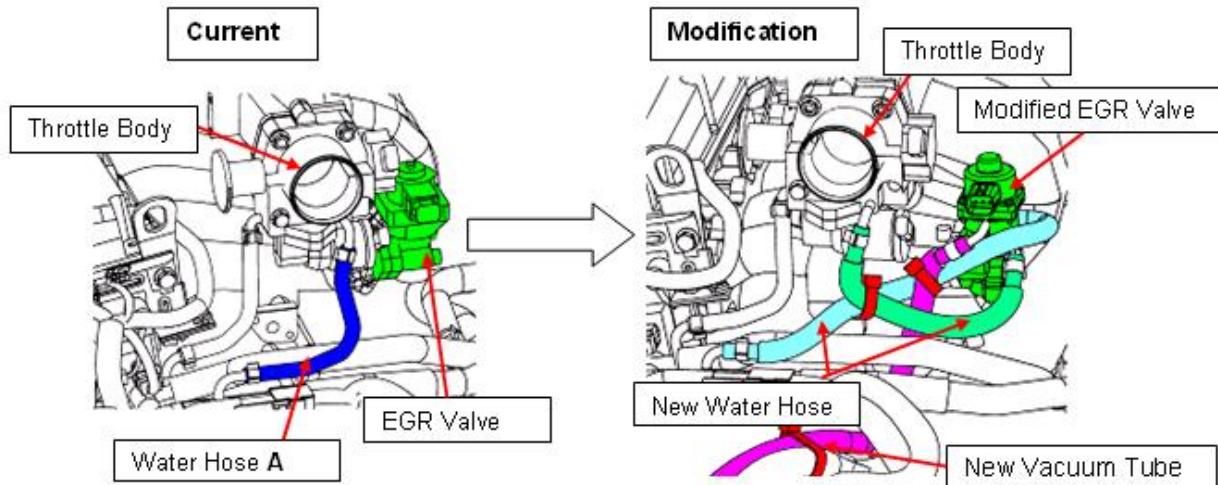

Vacuum tube routing

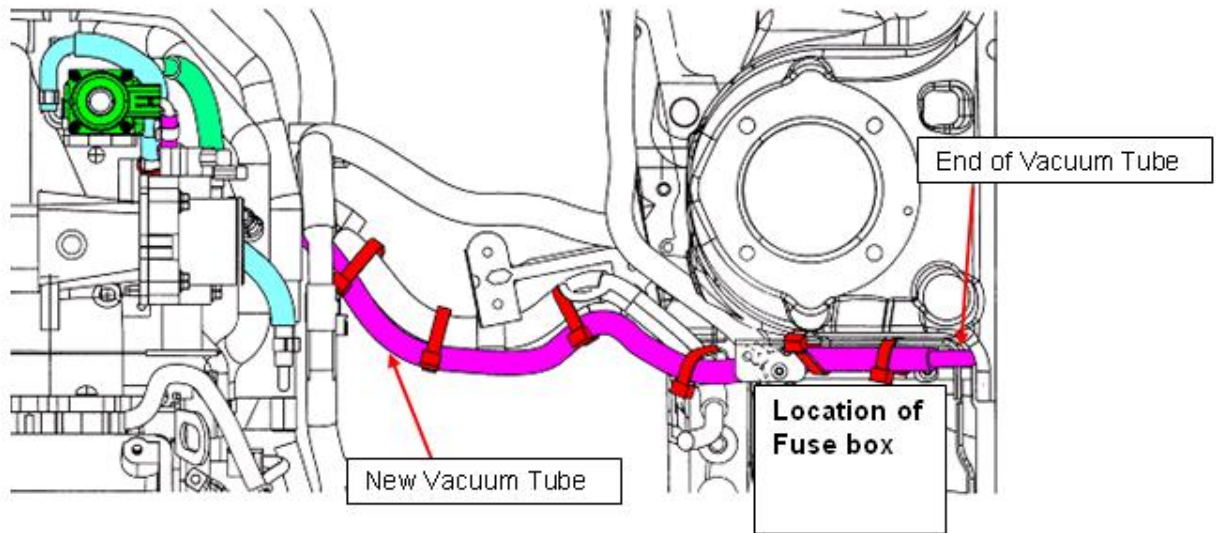

CONSUMER NOTICE: Consumers should not assume this bulletin applies to their vehicle or that their vehicle will develop the described concern. To determine if the information applies, consumers should contact their nearest authorized Mazda dealership.

Parts Information

The kit (ZMY1 18 W00) should be inspected to ensure that all components are present.

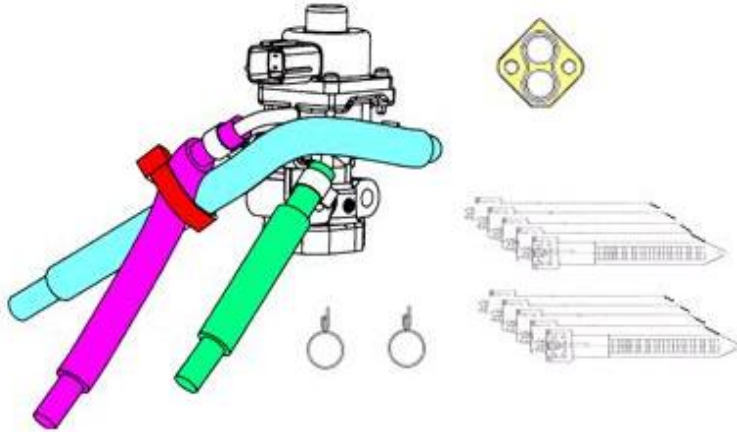
EGR VALVE KIT

- 1 EGR valve
- 10 tie-wraps
- 2 clamps
- 1 EGR gasket

Repair Procedure

WARNING: Allow the engine to sufficiently cool down before performing this repair.

Disassembly

1. Record the customer's preset radio stations.
2. Drain 2 litres of coolant from the cooling system via the radiator drain, making sure to securely retighten the drain afterwards.
3. Remove the battery, the air cleaner case, the air intake hose and the battery tray. Note: the drained coolant will be reused.

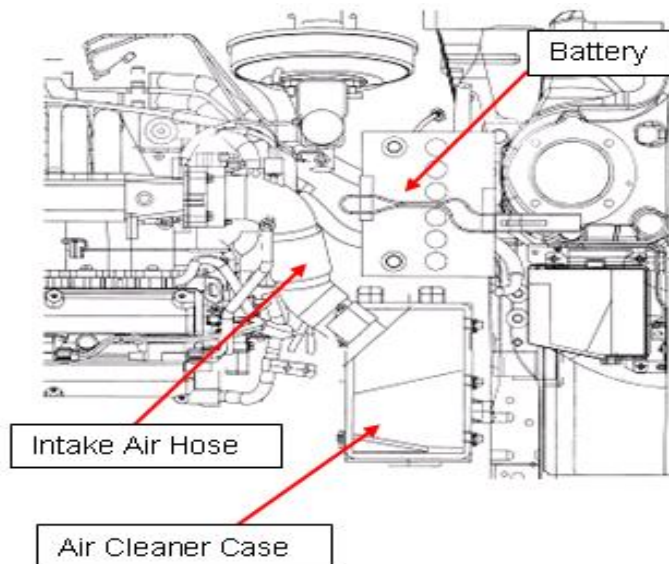

CONSUMER NOTICE: Consumers should not assume this bulletin applies to their vehicle or that their vehicle will develop the described concern. To determine if the information applies, consumers should contact their nearest authorized Mazda dealership.

4. Remove the water hose.

Note: The following figure shows the locations where the water hoses will be removed

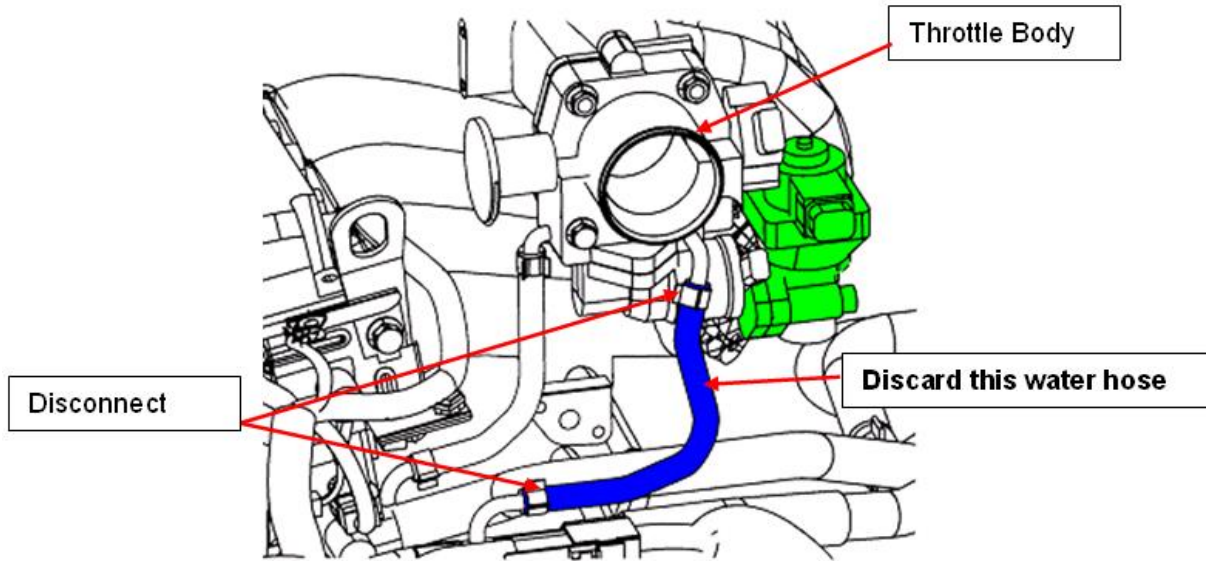

5. Remove the EGR valve and gasket.

Note: Discard the gasket.

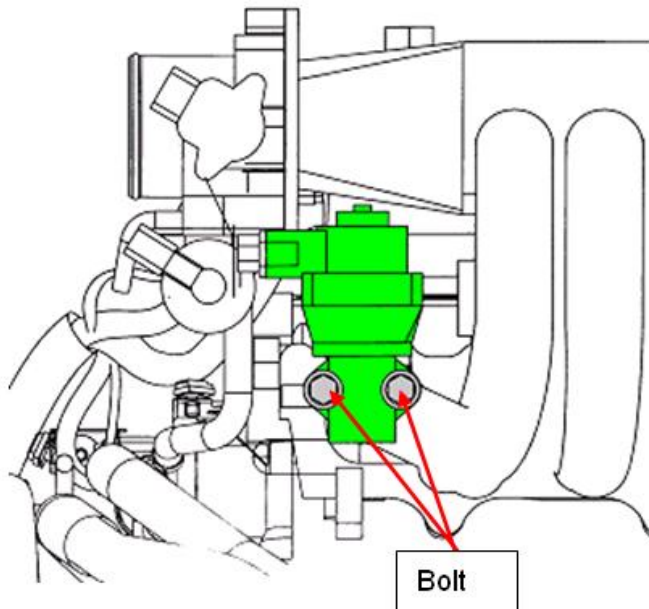

Installation

1. Apply glycerin to a new EGR gasket and fit the gasket to the EGR valve. Position the EGR valve.

Note:

- The glycerin is applied to the EGR gasket to keep it positioned properly and securely on the EGR valve.

CONSUMER NOTICE: Consumers should not assume this bulletin applies to their vehicle or that their vehicle will develop the described concern. To determine if the information applies, consumers should contact their nearest authorized Mazda dealership.

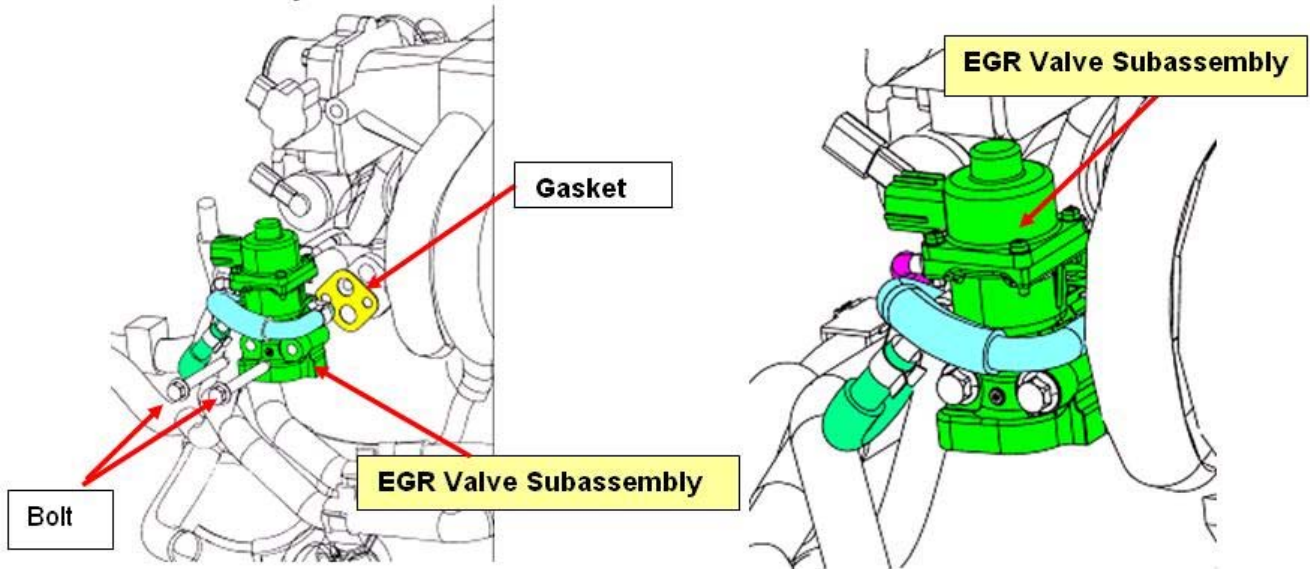

Note:

- Make sure that the EGR gasket has been fitted correctly.

2. Route the vacuum tube under the harness and heater hose as follows.

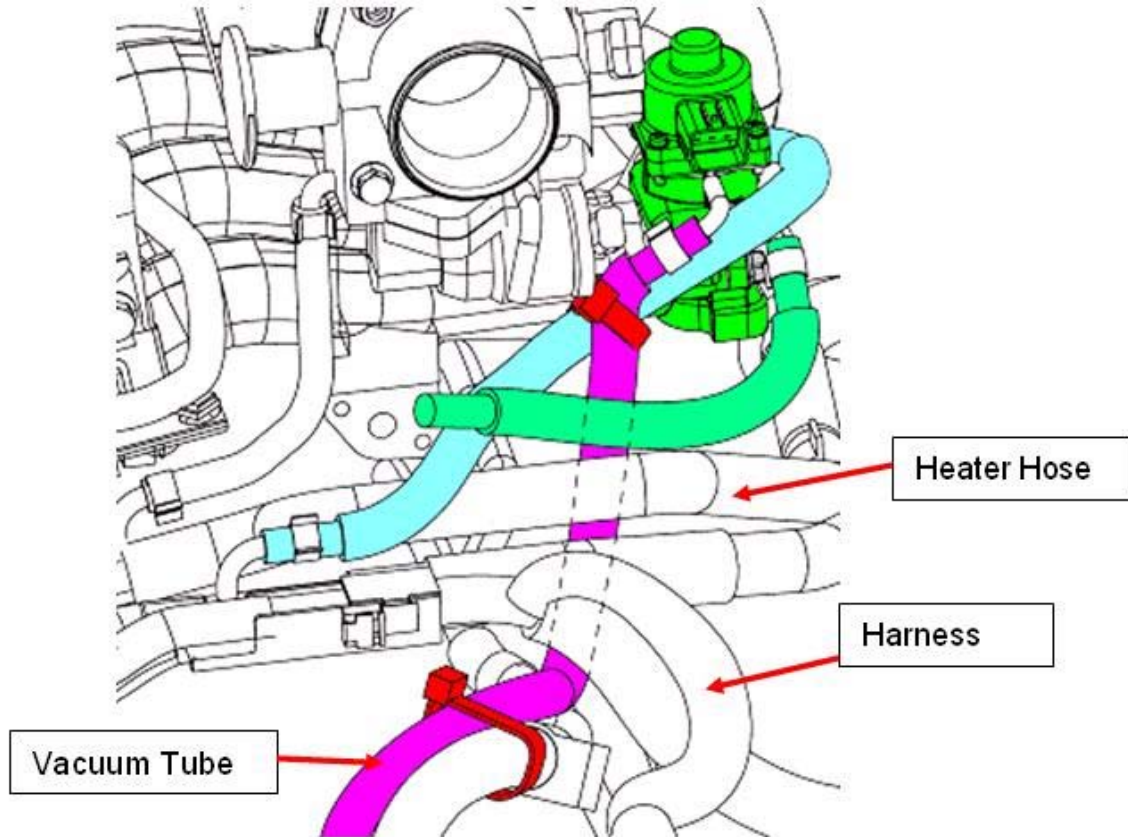

CONSUMER NOTICE: Consumers should not assume this bulletin applies to their vehicle or that their vehicle will develop the described concern. To determine if the information applies, consumers should contact their nearest authorized Mazda dealership.

3. Install the water hose as below.
 - 1) Insert the water hose into the bypass pipe.
 - 2) Insert the water hose into the throttle body.

Note:

- Use new clamps to secure the water hoses.
- The clamp holders should be removed from the locations where the new clamps are fitted, and then make sure that the water hose is securely fitted.

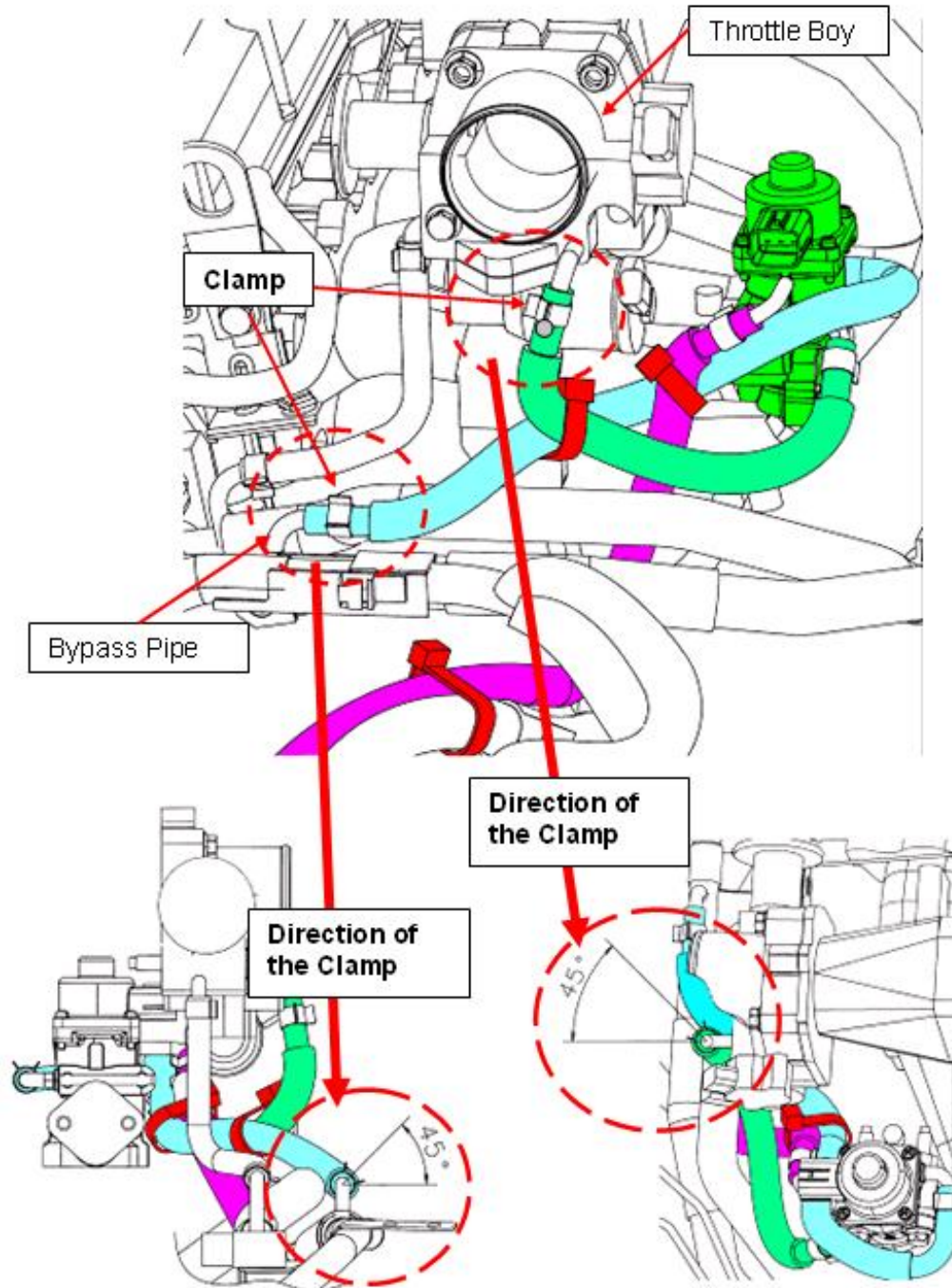

CONSUMER NOTICE: Consumers should not assume this bulletin applies to their vehicle or that their vehicle will develop the described concern. To determine if the information applies, consumers should contact their nearest authorized Mazda dealership.

4. Secure the water hoses as shown in the following picture using tie wraps.

Caution:

- Ensure that there is approx. 40 mm clearance between the water hose and brake pipe.

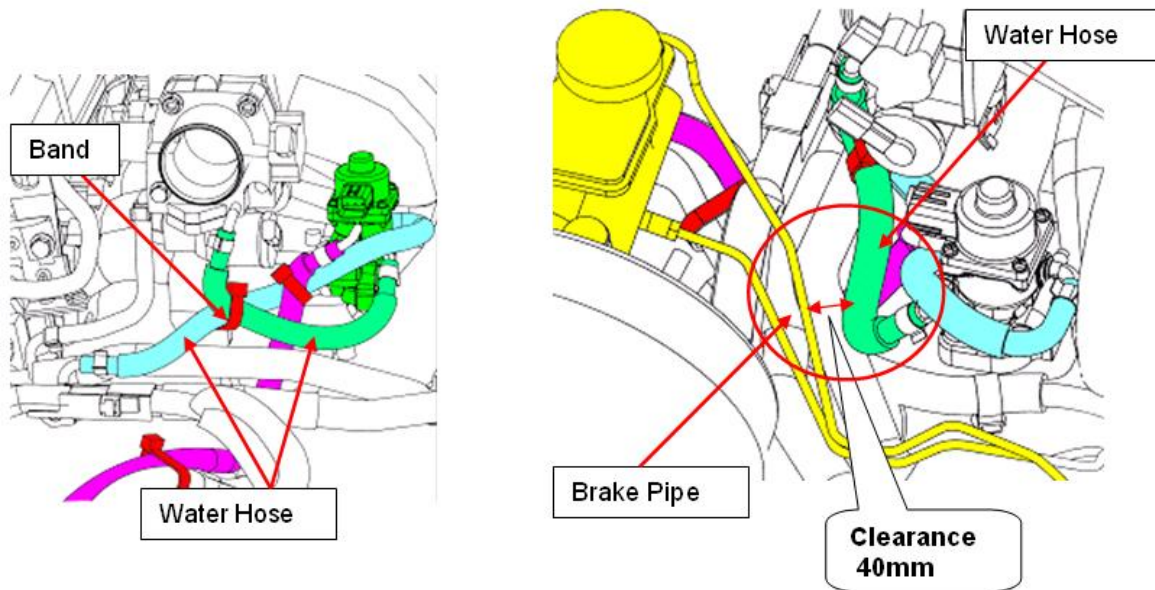

5. Route the vacuum tube as shown below, and secure it to the harness and bracket using seven tie-wraps. (Cut off the surplus portion of the tie-wraps). Insert the end of the vacuum tube between bracket **B** and the left fender, making certain that it points downwards. Route the vacuum tube under bracket **A**.

Note:

- When routing the vacuum tube, it is not necessary to remove the fuse box

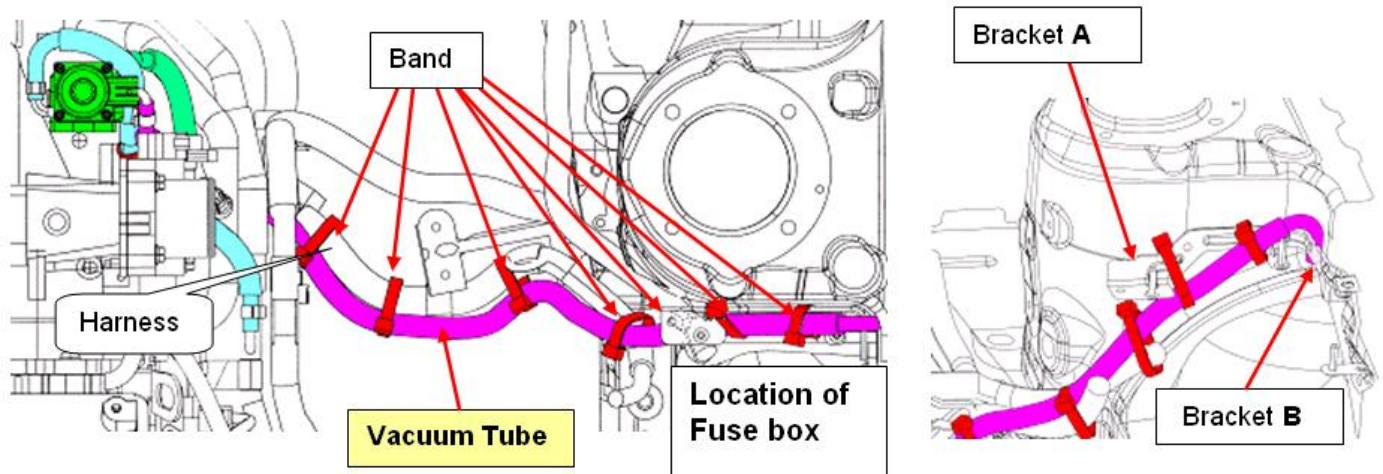

6. Make sure that the water hose is secured with the clamp.

7. Re-install the battery tray, air cleaner case, intake air hose and battery.

CONSUMER NOTICE: Consumers should not assume this bulletin applies to their vehicle or that their vehicle will develop the described concern. To determine if the information applies, consumers should contact their nearest authorized Mazda dealership.

Number 01-07-46	Date Issued 12/07	Date Revised
------------------------	--------------------------	---------------------

8. Refill the coolant which was drained from the radiator.

1) Refill the coolant and close the radiator cap.

Note:

- **You can't fill all the coolant at a time, so repeat step 1) to 4) to refill all the drained coolant.**

2) Warm up and rev-up the engine.

3) Stop the engine and allow it to cool down.

Note:

- **The coolant level goes down when the engine becomes cold.**

4) Warm up and rev-up the engine.

5) Stop the engine and allow it to cool down.

6) Refill the coolant into the radiator reservoir tank until the coolant level comes up to "FULL".

Note:

- **Reuse the coolant which has been drained.**

7) Make sure there is no coolant leakage and the radiator drain and water hose connected locations are no problem

9. Confirm that the engine idle speed is correct.

Note:

- **If the idle speed is not as specified, this likely indicates the presence of an air leak, possibly an improperly installed throttle body, EGR valve, gasket and/or intake air hose. Check to see if these parts are fitted properly, making sure that the old gaskets have been completely removed.**

10. Verify that no related PCM trouble codes are set.

11. Reset the customer's preset radio stations.

CONSUMER NOTICE: Consumers should not assume this bulletin applies to their vehicle or that their vehicle will develop the described concern. To determine if the information applies, consumers should contact their nearest authorized Mazda dealership.